

ELEVATION
SCALE 1:20

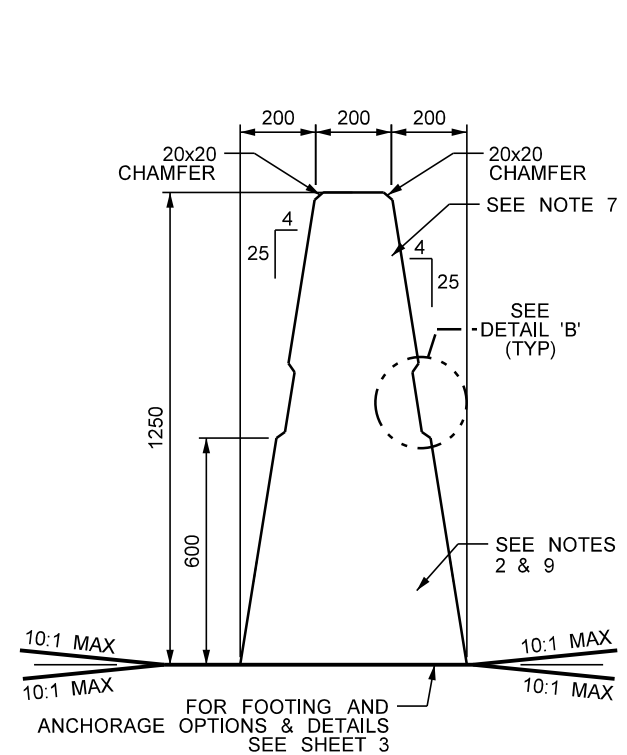

SECTION 'A-A'
SCALE 1:20

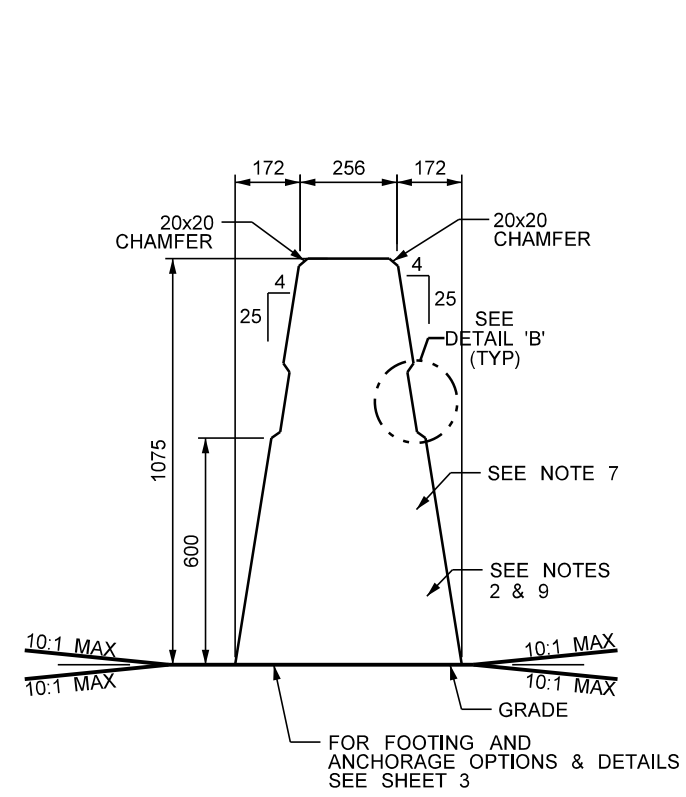

SECTION 'B-B'
SCALE 1:20

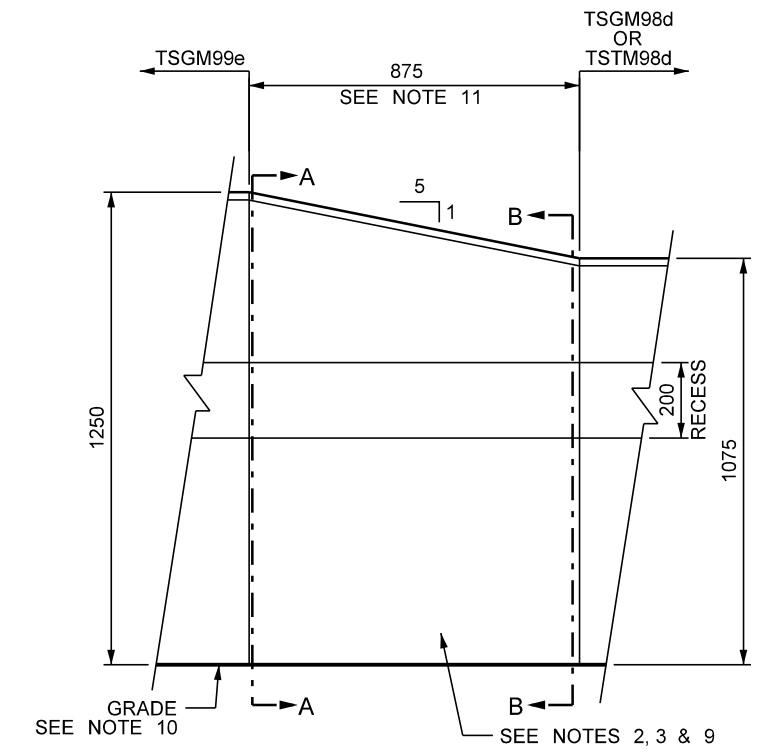

ELEVATION
SCALE 1:20

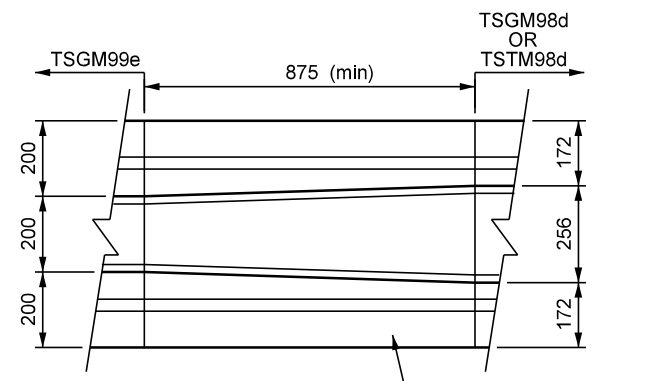

PLAN
SCALE 1:20

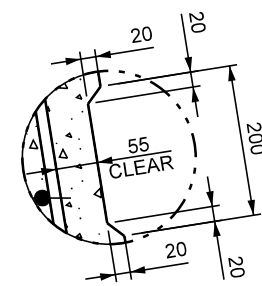

DETAIL 'B'
SCALE 1:10

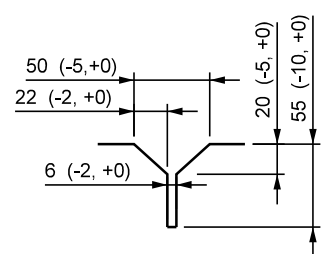

HAND FORMED BARRIER
SCALE 1:5

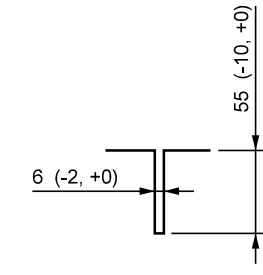

SLIP FORMED BARRIER (SAW CUT)
SCALE 1:5

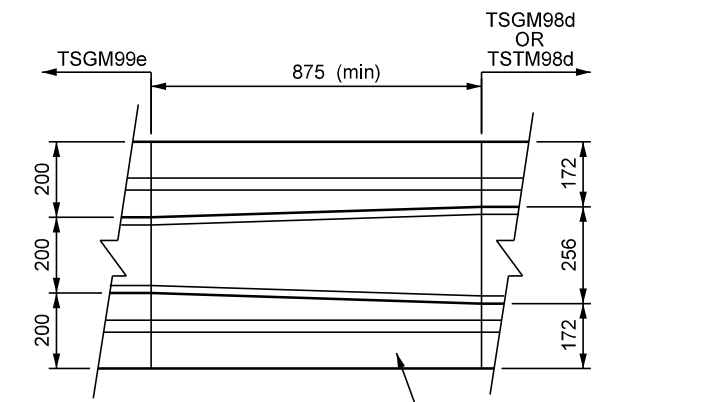

PLAN
SCALE 1:20

END SECTION DETAILS

NOTES:

1. ALL SCALES ARE APPROXIMATE.
2. LONGITUDINAL REINFORCING NOT SHOWN FOR CLARITY.
3. FORMED OR CUT CONTRACTION JOINTS SHALL BE CREATED AT EACH PLACE WHERE THE BARRIER SHAPE CHANGES, TO MATCH ADJACENT PAVEMENT JOINT SPACING, OR AT A MAXIMUM OF 6000 mm.
4. ALL DIMENSIONS ARE IN MILLIMETRES UNLESS OTHERWISE INDICATED.
5. THE ORIGINAL SEALED AND SIGNED DRAWING IS IN TRAFFIC ENGINEERING.
6. ALL REINFORCING SHALL HAVE MINIMUM 75 mm COVER, UNLESS OTHERWISE NOTED.
7. CONCRETE: CSA A23.1, EXPOSURE CLASS C-1, AIR CONTENT CATEGORY 1, COMPRESSIVE STRENGTH: BARRIER ≥ 45 MPa AND FOOTING ≥ 35 MPa AT 28 DAYS.
8. SEE SHEET 4 FOR REINFORCING DETAILS.
9. TRANSVERSE REINFORCING NOT SHOWN FOR CLARITY.
10. SEE SHEET 3 FOR BELOW GRADE DESIGN OPTIONS.
11. END SECTION SPACING MUST CONTINUE INTO ADJACENT SECTION(S) OF BARRIER AS NECESSARY.

CONTRACTION JOINT DETAILS

REVISIONS		
DATE	DESCRIPTION	BY



**MANITOBA
CONSTRAINED WIDTH
CONSTANT SLOPE
BARRIER - MEDIUM
TL-5 TRANSITION
(1250 TO 1075)**

SHEET NO: 1 OF 4	DATE: 2020 - 08
DESIGNED BY:	H. LARSEN
DRAWN BY:	L. LIEBRECHT
REVIEWED BY:	N. JOYAL
TSTM99e	

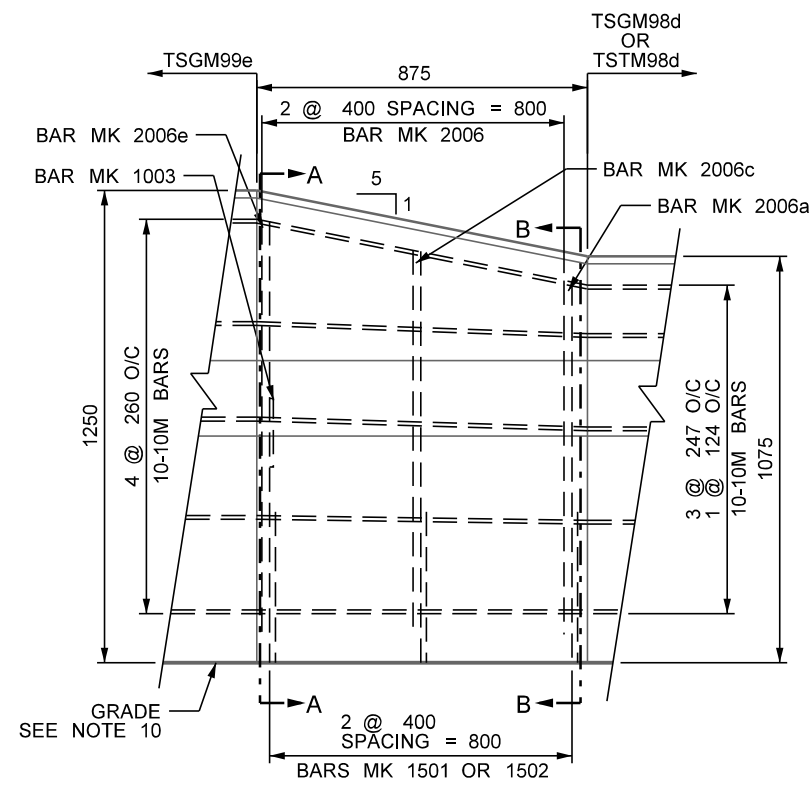

ELEVATION
SCALE 1:20

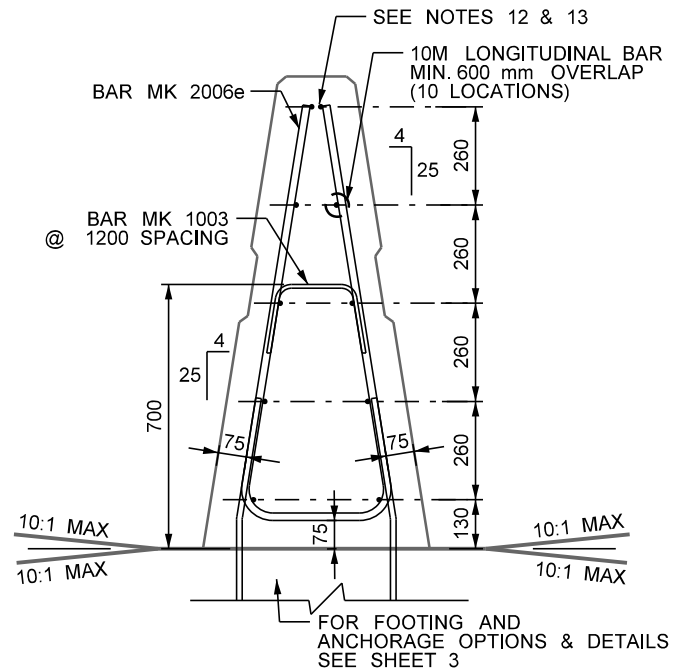

SECTION 'A-A'
SCALE 1:20

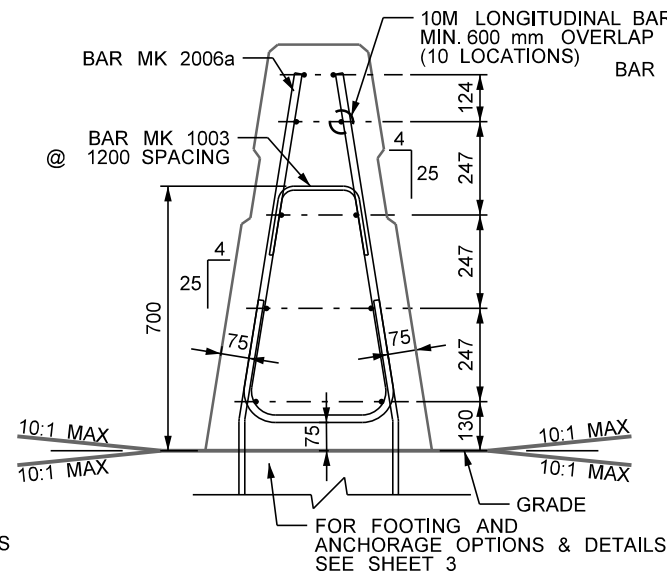

SECTION 'B-B'
SCALE 1:20

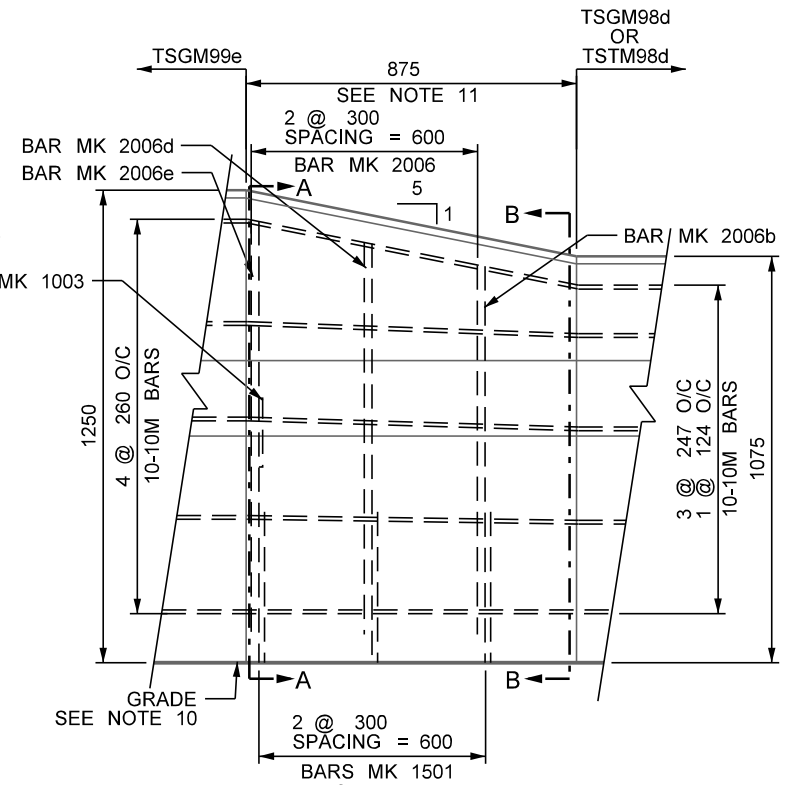

ELEVATION
SCALE 1:20

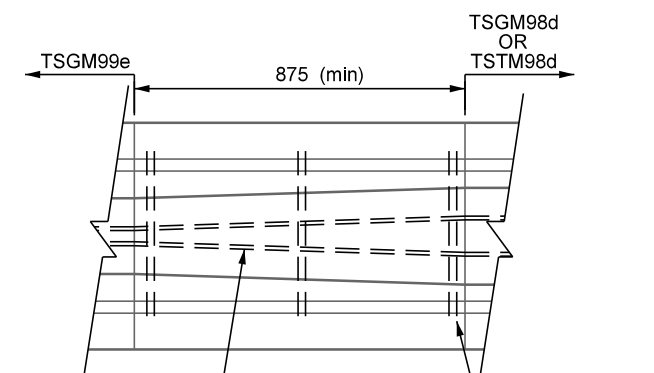

PLAN
SCALE 1:20

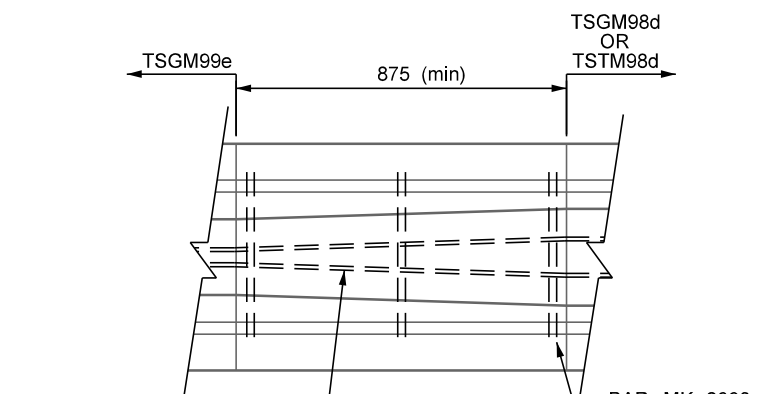

PLAN
SCALE 1:20

INTERIOR SECTION DETAILS

END SECTION DETAILS

NOTES:

1. ALL SCALES ARE APPROXIMATE.
2. LONGITUDINAL REINFORCING NOT SHOWN FOR CLARITY.
3. FORMED OR CUT CONTRACTION JOINTS SHALL BE CREATED AT EACH PLACE WHERE THE BARRIER SHAPE CHANGES, TO MATCH ADJACENT PAVEMENT JOINT SPACING, OR AT A MAXIMUM OF 6000 mm.
4. ALL DIMENSIONS ARE IN MILLIMETRES UNLESS OTHERWISE INDICATED.
5. THE ORIGINAL SEALED AND SIGNED DRAWING IS IN TRAFFIC ENGINEERING.
6. ALL REINFORCING SHALL HAVE MINIMUM 75 mm COVER, UNLESS OTHERWISE NOTED.
7. CONCRETE: CSA A23.1, EXPOSURE CLASS C-1, AIR CONTENT CATEGORY 1, COMPRESSIVE STRENGTH: BARRIER ≥ 45 MPa and FOOTING ≥ 35 MPa AT 28 DAYS.
8. SEE SHEET 4 FOR REINFORCING DETAILS.
9. TRANSVERSE REINFORCING NOT SHOWN FOR CLARITY.
10. SEE SHEET 3 FOR BELOW GRADE DESIGN OPTIONS.
11. END SECTION SPACING MUST CONTINUE INTO ADJACENT SECTION(S) OF BARRIER AS NECESSARY.
12. ALTERNATE LONGITUDINAL REINFORCEMENT OF TOP TWO BARS MAY BE ONE (1) SINGLE 15M BAR.
13. LONGITUDINAL BARS SHALL BE SEPARATED FROM EACH OTHER A MINIMUM DISTANCE OF $1\frac{1}{2}$ TIMES THE MAXIMUM AGGREGATE SIZE; ADJUST PLACEMENT AS REQUIRED.

REVISIONS		
DATE	DESCRIPTION	BY

Manitoba
Infrastructure
Traffic Engineering



MANITOBA
CONSTRAINED WIDTH
CONSTANT SLOPE
BARRIER - MEDIUM
TL-5 TRANSITION
(1250 TO 1075)

SHEET NO: 2 OF 4	DATE: 2020 - 08
DESIGNED BY:	H. LARSEN
DRAWN BY:	L. LIEBRECHT
REVIEWED BY:	N. JOYAL

TSTM99e

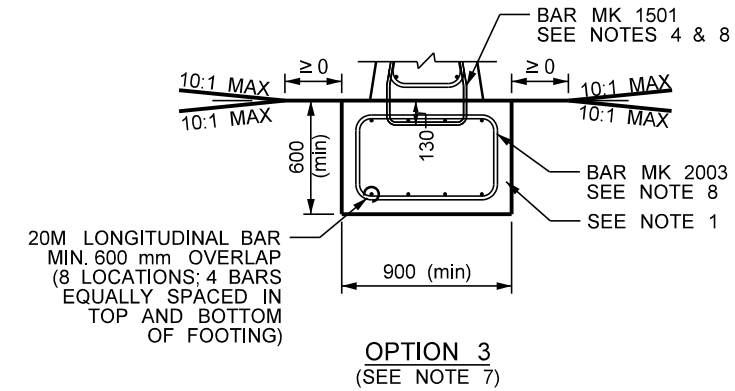
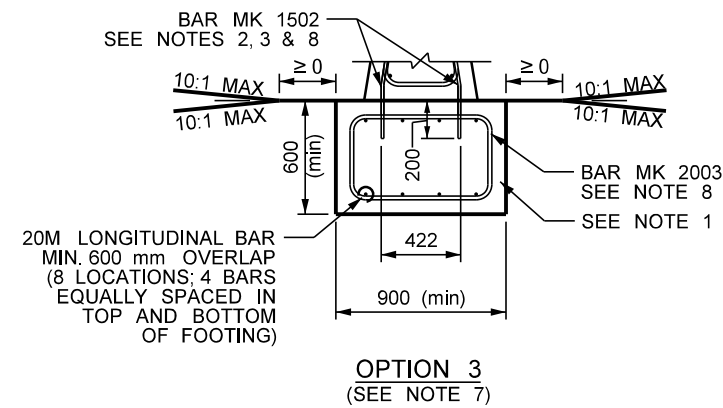
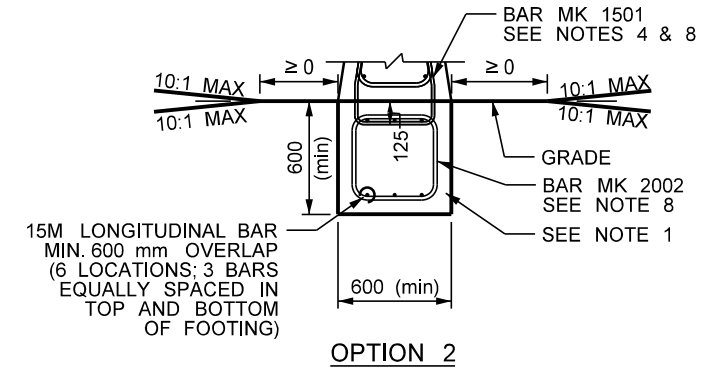
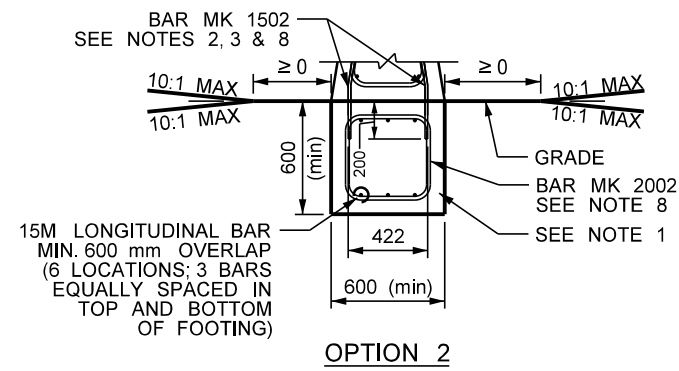
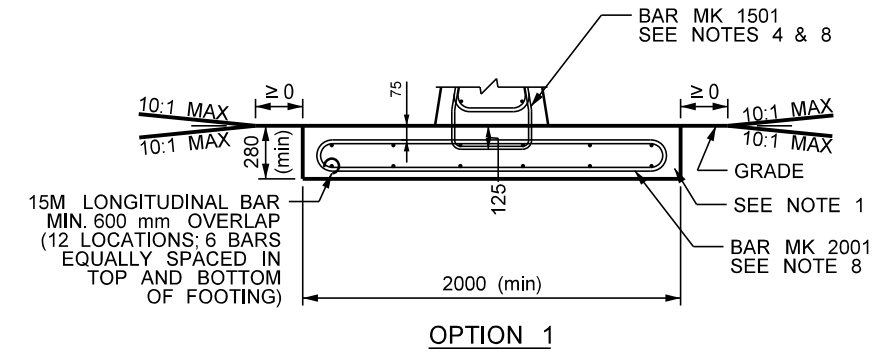
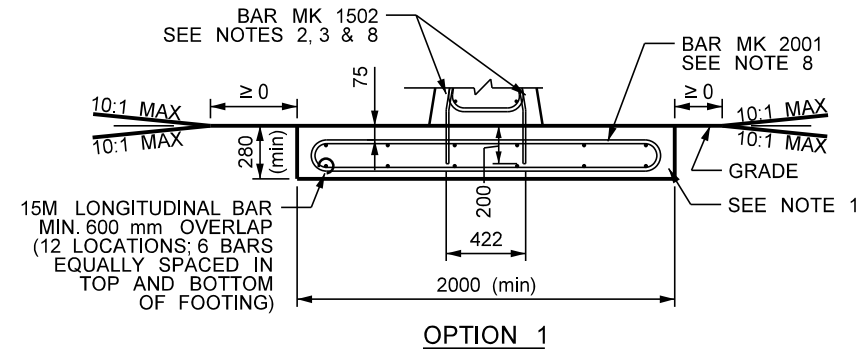

SECTION 'A-A'
EXISTING FOOTING
SCALE 1:40

SECTION 'A-A'
NEW FOOTING
SCALE 1:40

NOTES:

1. NEW OR EXISTING REINFORCED CONCRETE: CSA A23.1, EXPOSURE CLASS C-1, AIR CONTENT CATEGORY 1, COMPRESSIVE STRENGTH FOOTING ≥ 35 MPa AT 28 DAYS.
2. HOLES IN FOOTING SHALL BE DRILLED VERTICALLY 2 mm LARGER THAN REINFORCING.
3. HOLES IN FOOTING SHALL BE PREPARED FOR EPOXY (HILTI HIT RE 500, OR APPROVED ALTERNATIVE) AS DIRECTED BY MANUFACTURER.
4. STIRRUP SHALL BE SECURELY ATTACHED TO REBAR.
5. ALL DIMENSIONS IN MILLIMETRES UNLESS OTHERWISE INDICATED.
6. SEE SHEET 4 FOR REINFORCEMENT DETAILS.
7. OPTION 3 MUST BE USED FOR END SECTION OF BARRIER.
8. SPACING TO MATCH BAR MK 2006.
9. ALL REINFORCING SHALL HAVE MINIMUM 75 mm COVER, UNLESS OTHERWISE NOTED.

REVISIONS		
DATE	DESCRIPTION	BY



MANITOBA
CONSTRAINED WIDTH
CONSTANT SLOPE
BARRIER - MEDIAN
TL-5 TRANSITION
(1250 TO 1075)

SHEET NO: 3 OF 4	DATE: 2020 - 08
DESIGNED BY:	H. LARSEN
DRAWN BY:	L. LIEBRECHT
REVIEWED BY:	N. JOYAL

TSTM99e

MARK	TYPE	PIN DIAMETER (mm)	TOTAL LENGTH (mm)	MASS			BENDING DIAGRAM																								
				kg	kg/m																										
					INTERIOR SEC.	END SEC.																									
1003	BENT	65	548	0.43	0.36	0.36																									
1501	BENT	65	1439	2.26	5.65	7.53																									
1502	BENT	65	604	0.95	4.75	6.33																									
2001	BENT	125	4173	9.83	24.58	--																									
2002	BENT	125	2285	5.38	13.45	--																									
2003	BENT	125	2883	6.79	16.98	22.63																									
							DIMENSION																								
							<table border="1"> <thead> <tr> <th>A</th> <th>B</th> <th>C</th> <th>D</th> </tr> </thead> <tbody> <tr> <td>947</td> <td>937</td> <td>150</td> <td>125</td> </tr> <tr> <td>987</td> <td>975</td> <td>156</td> <td>112</td> </tr> <tr> <td>1028</td> <td>1015</td> <td>162</td> <td>99</td> </tr> <tr> <td>1048</td> <td>1035</td> <td>166</td> <td>93</td> </tr> <tr> <td>1114</td> <td>1100</td> <td>176</td> <td>72</td> </tr> </tbody> </table>	A	B	C	D	947	937	150	125	987	975	156	112	1028	1015	162	99	1048	1035	166	93	1114	1100	176	72
A	B	C	D																												
947	937	150	125																												
987	975	156	112																												
1028	1015	162	99																												
1048	1035	166	93																												
1114	1100	176	72																												
2006a	BENT	125	2216	5.22	5.97	--																									
2006b	BENT	125	2297	5.41	--	6.18																									
2006c	BENT	125	2378	5.60	6.40	--																									
2006d	BENT	125	2419	5.70	--	6.51																									
2006e	BENT	125	2550	6.00	6.86	6.86																									

LONGITUDINAL REINFORCING - MASS (kg/m)						
BAR	INTERIOR SECTION	END SECTION	FOOTING			
			OPTION 1	OPTION 2	OPTION 3	
10M	8.24	8.24	--	--	--	
15M	--	--	19.78	9.89	--	
20M	--	--	--	--	19.78	

NOTES:

- ALL DIMENSIONS GIVEN IN BENDING DIAGRAM ARE OUT TO OUT, EXCEPT RADII AND EXTENSIONS ON 90°, 135° & 180° HOOKS. EXTENSIONS ON 90°, 135° & 180° HOOKS ARE THE "A" OR "G" DIMENSIONS FOR THE STANDARD 90°, 135° & 180° HOOKS REFERENCED FROM THE RSIC "MANUAL OF STANDARD PRACTICE". RADII ARE INSIDE DIMENSIONS. ALL REINFORCING STEEL BENDS AND HOOKS SHALL CONFORM TO CLAUSE 6.6.2 OF CSA A23.1 UNLESS NOTED OTHERWISE IN THE BILL OF REINFORCING STEEL.
- ALL REINFORCING STEEL SHALL BE DEFORMED STEEL UNLESS NOTED OTHERWISE IN THE BILL OF REINFORCING STEEL.
- ALL REINFORCING STEEL SHALL CONFORM TO CSA G30.18-M92 "BILLET STEEL BARS FOR CONCRETE REINFORCEMENT" GRADE 400W, UNLESS NOTED OTHERWISE IN THE BILL OF REINFORCING STEEL.
- LIKE BARS SHALL BE BUNDLED, SECURELY TIED, AND IDENTIFIED AS TO MARK No. BY APPROPRIATE MEANS. ALL OTHER ITEMS TO BE IDENTIFIED IN A SIMILAR FASHION.
- BARS MARKED WITH THE SUFFIX "P" SHALL BE PLAIN UNDEFORMED BARS IN ACCORDANCE WITH CAN/CSA G40.21-M92 GRADE 300W.
- ALL BARS SHALL BE BENT IN ACCORDANCE WITH THE FOLLOWING DETAIL:

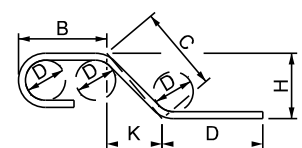

REVISIONS		
DATE	DESCRIPTION	BY



**MANITOBA
CONSTRAINED WIDTH
CONSTANT SLOPE
BARRIER - MEDIAN
TL-5 TRANSITION
(1250 TO 1075)**

SHEET NO: 4 OF 4	DATE: 2020 - 08
DESIGNED BY: H. LARSEN	
DRAWN BY: L. LIEBRECHT	
REVIEWED BY: N. JOYAL	
TSTM99e	