

**SECTION 'A-A'**  
INTERIOR SECTION  
SCALE 1:20

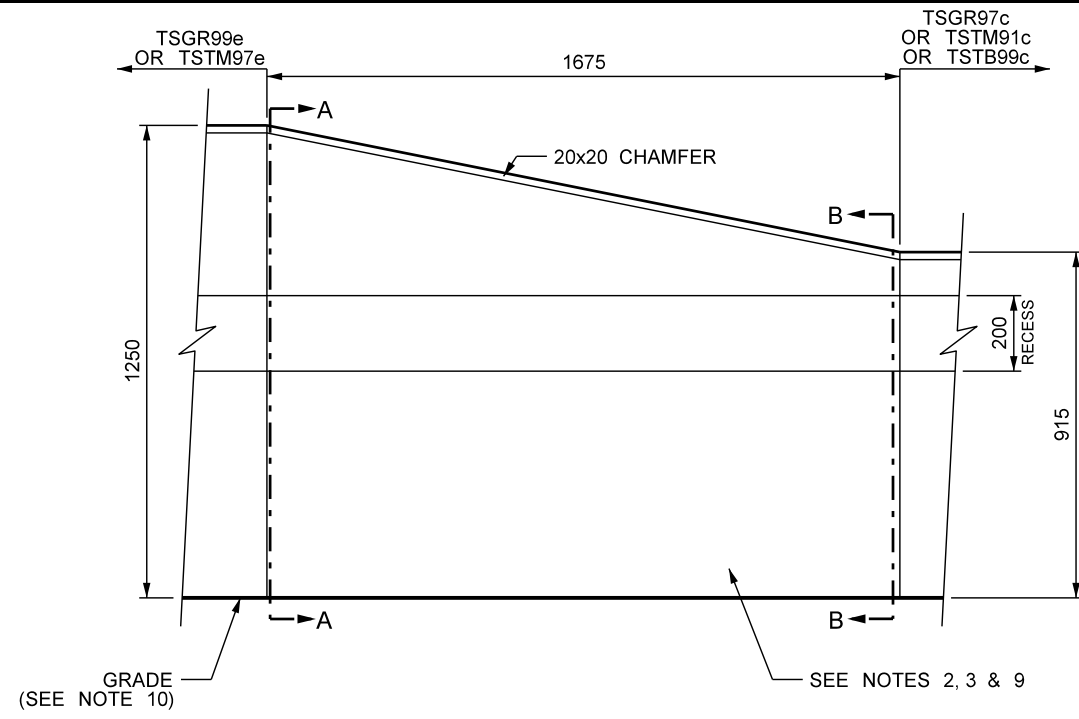

**ELEVATION**  
SCALE 1:20

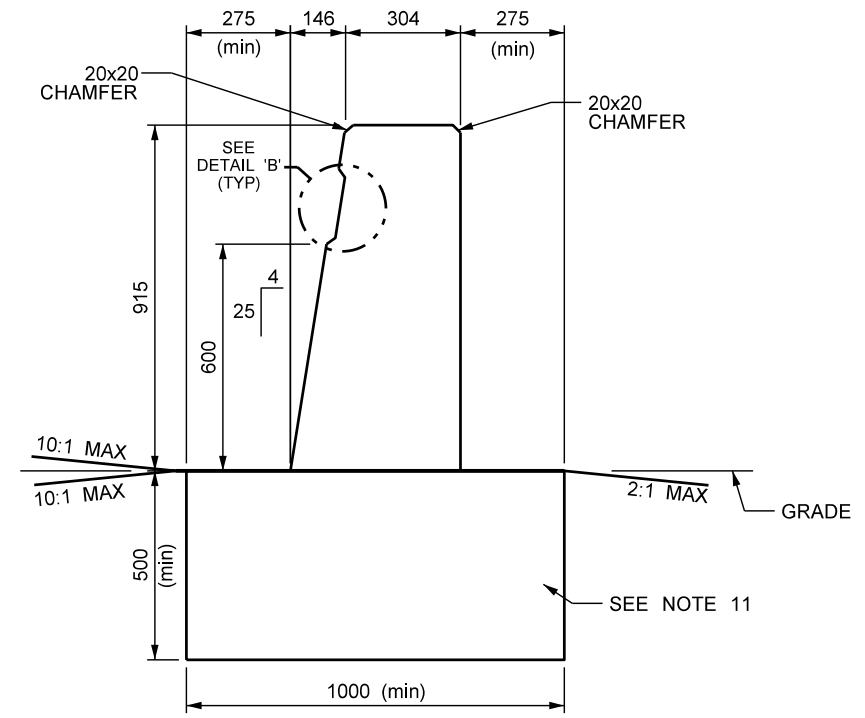

**SECTION 'B-B'**  
INTERIOR SECTION  
SCALE 1:20

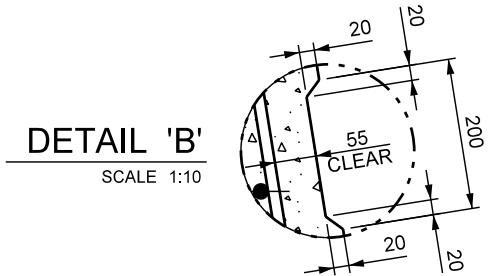

**DETAIL 'B'**  
SCALE 1:10

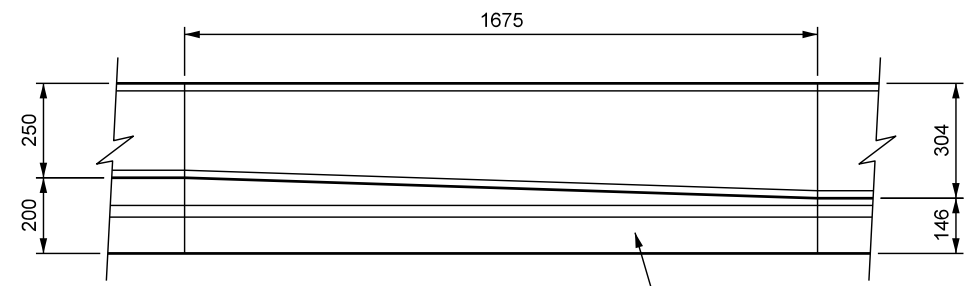

**PLAN**  
SCALE 1:20

**INTERIOR SECTION DETAILS**

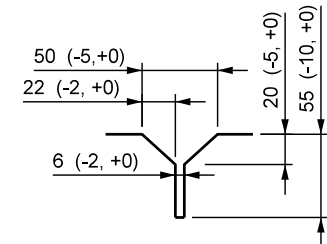

**HAND FORMED BARRIER**  
SCALE 1:5

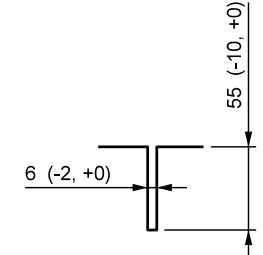

**SLIP FORMED BARRIER (SAW CUT)**  
SCALE 1:5

**CONTRACTION JOINT DETAILS**

**NOTES:**

1. ALL SCALES ARE APPROXIMATE.
2. LONGITUDINAL REINFORCING NOT SHOWN FOR CLARITY.
3. FORMED OR CUT CONTRACTION JOINTS SHALL BE CREATED AT EACH PLACE WHERE THE BARRIER SHAPE CHANGES, TO MATCH ADJACENT PAVEMENT JOINT SPACING, OR AT A MAXIMUM SPACING OF 6000 mm.
4. ALL DIMENSIONS ARE IN MILLIMETRES UNLESS OTHERWISE INDICATED.
5. THE ORIGINAL SEALED AND SIGNED DRAWING IS IN TRAFFIC ENGINEERING.
6. ALL REINFORCING SHALL HAVE MINIMUM 75 mm COVER, UNLESS OTHERWISE NOTED.
7. CONCRETE: CSA A23.1, EXPOSURE CLASS C-1, AIR CONTENT CATEGORY 1, COMPRESSIVE STRENGTH: BARRIER  $\geq 45$  MPA AND FOOTING  $\geq 35$  MPA, AT 28 DAYS.
8. SEE SHEET 5 FOR REINFORCING DETAILS.
9. TRANSVERSE REINFORCING NOT SHOWN FOR CLARITY.
10. SEE SECTIONS 'A-A' & 'B-B' FOR BELOW GRADE DESIGN OPTIONS.
11. NEW OR EXISTING REINFORCED CONCRETE FOOTING: CSA A23.1, EXPOSURE CLASS C-1, AIR CONTENT CATEGORY 1, COMPRESSIVE STRENGTH  $\geq 35$  MPa, AT 28 DAYS.

REVISIONS		
DATE	DESCRIPTION	BY



**MANITOBA**  
CONSTRAINED WIDTH  
CONSTANT SLOPE  
BARRIER - ROADSIDE  
TL-5 TO TL-4 TRANSITION  
(1250 TO 915)

SHEET NO: 1 OF 5	DATE: 2020 - 11
DESIGNED BY:	H. LARSEN
DRAWN BY:	L. LIEBRECHT
REVIEWED BY:	N. JOYAL
<b>TSTG97e</b>	

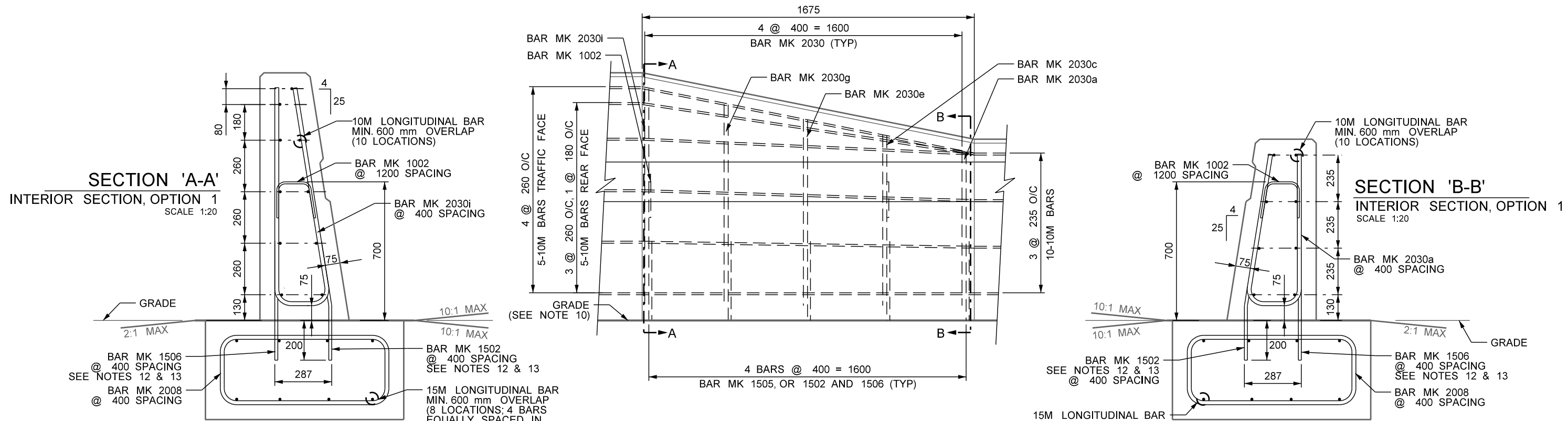

**ELEVATION**  
SCALE 1:20

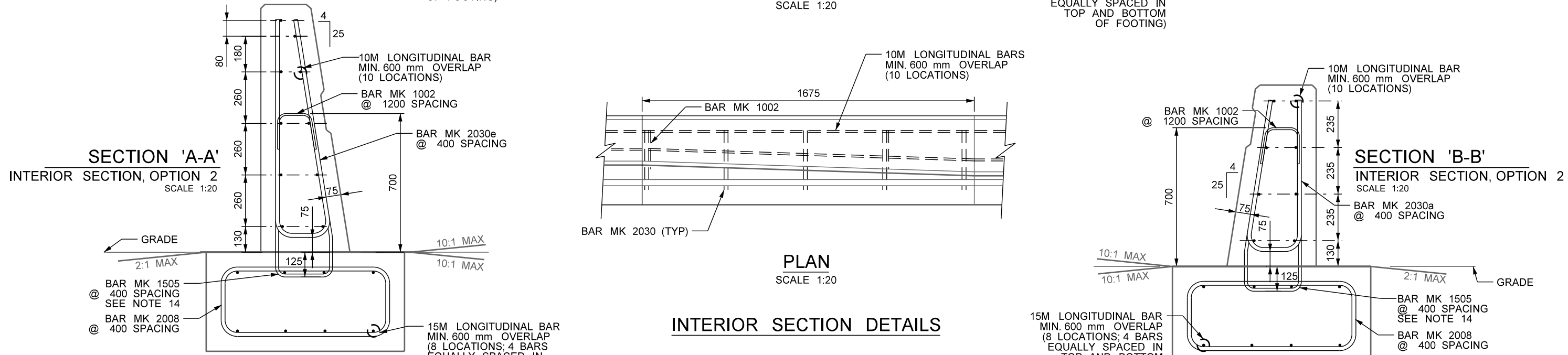

**PLAN**  
SCALE 1:20

**INTERIOR SECTION DETAILS**

**NOTES:**

1. ALL SCALES ARE APPROXIMATE.
2. LONGITUDINAL REINFORCING NOT SHOWN FOR CLARITY.
3. FORMED OR CUT CONTRACTION JOINTS SHALL BE CREATED AT EACH PLACE WHERE THE BARRIER SHAPE CHANGES, TO MATCH ADJACENT PAVEMENT JOINT SPACING, OR AT A MAXIMUM SPACING OF 6000 mm.
4. ALL DIMENSIONS ARE IN MILLIMETRES UNLESS OTHERWISE INDICATED.
5. THE ORIGINAL SEALED AND SIGNED DRAWING IS IN TRAFFIC ENGINEERING.
6. ALL REINFORCING SHALL HAVE MINIMUM 75 mm COVER, UNLESS OTHERWISE NOTED.
7. CONCRETE: CSA A23.1, EXPOSURE CLASS C-1, AIR CONTENT CATEGORY 1, COMPRESSIVE STRENGTH: BARRIER ≥ 45 MPA AND FOOTING ≥ 35 MPA, AT 28 DAYS.
8. SEE SHEET 5 FOR REINFORCING DETAILS.
9. TRANSVERSE REINFORCING NOT SHOWN FOR CLARITY.
10. SEE SECTIONS 'A-A' & 'B-B' FOR BELOW GRADE DESIGN OPTIONS.
11. NEW OR EXISTING REINFORCED CONCRETE FOOTING: CSA A23.1, EXPOSURE CLASS C-1, AIR CONTENT CATEGORY 1, COMPRESSIVE STRENGTH ≥ 35 MPa, AT 28 DAYS.
12. HOLES IN FOOTING SHALL BE DRILLED VERTICALLY 2 mm LARGER THAN REINFORCING.
13. HOLES IN FOOTING SHALL BE PREPARED FOR EPOXY (HILTI HIT RE 500, OR APPROVED ALTERNATIVE) AS DIRECTED BY MANUFACTURER.
14. STIRRUP SHALL BE SECURELY ATTACHED TO REBAR.

REVISIONS		
DATE	DESCRIPTION	BY



**MANITOBA**  
CONSTRAINED WIDTH  
CONSTANT SLOPE  
BARRIER - ROADSIDE  
TL-5 TO TL-4 TRANSITION  
(1250 TO 915)

SHEET NO: 2 OF 5	DATE: 2020 - 11
DESIGNED BY:	H. LARSEN
DRAWN BY:	L. LIEBRECHT
REVIEWED BY:	N. JOYAL
<b>TSTG97e</b>	

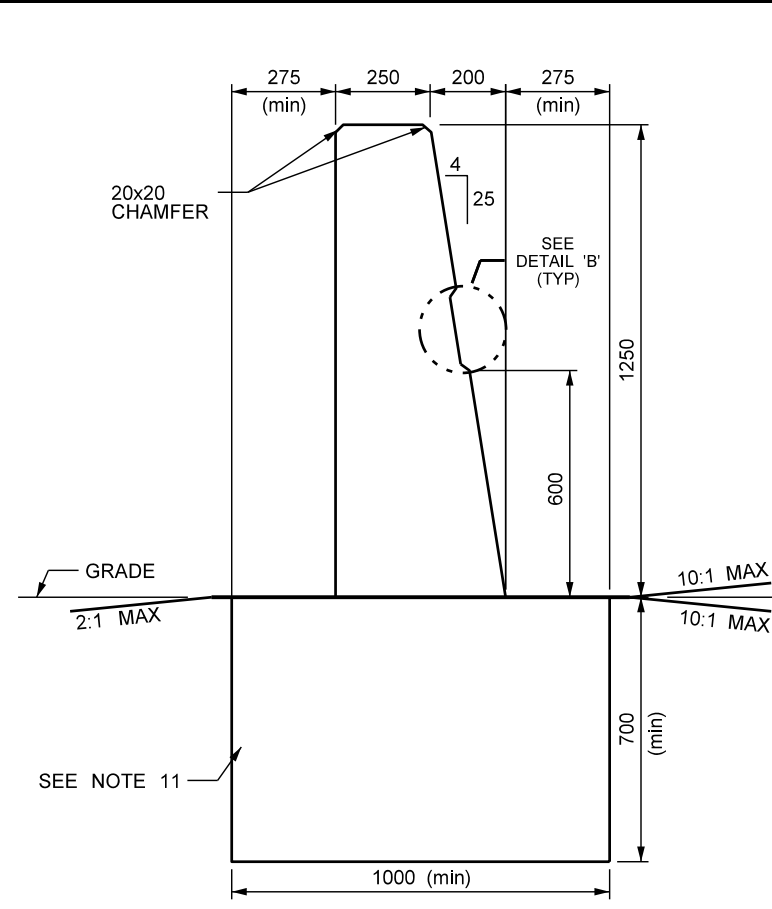

**SECTION 'C-C'**  
END SECTION  
SCALE 1:20

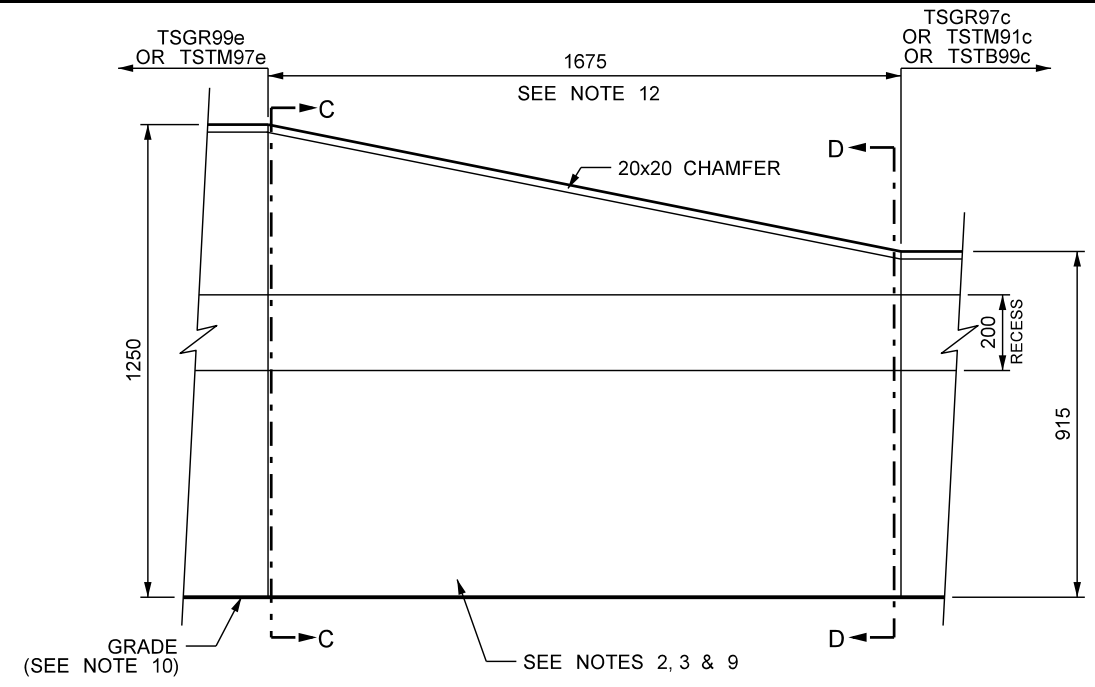

**ELEVATION**  
SCALE 1:20

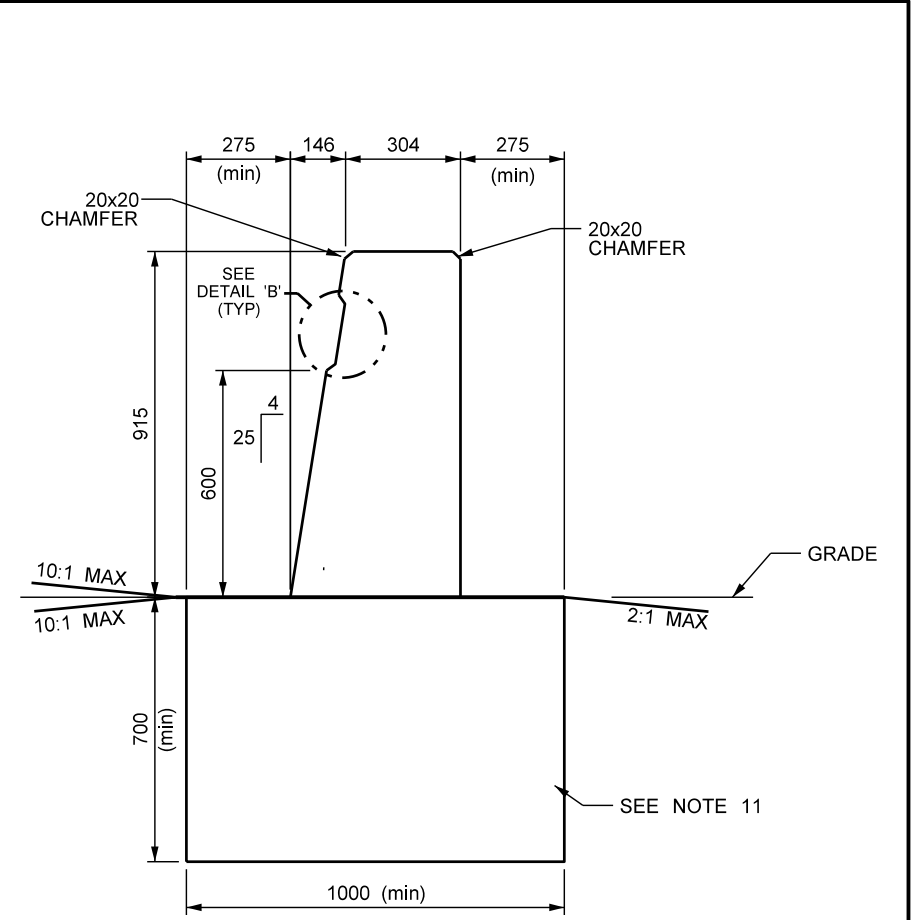

**SECTION 'D-D'**  
END SECTION  
SCALE 1:20

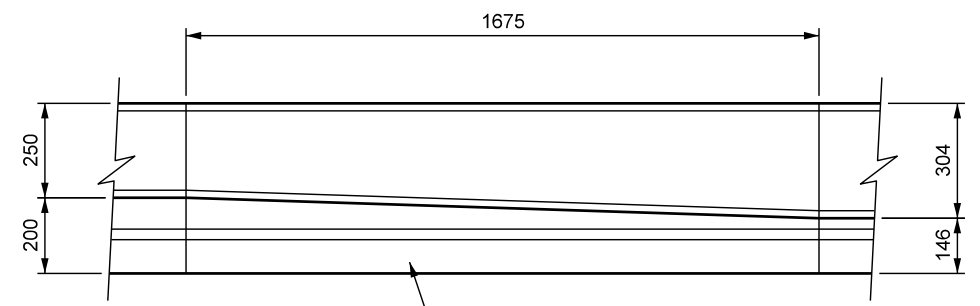

**PLAN**  
SCALE 1:20

**END SECTION DETAILS**

**NOTES:**

1. ALL SCALES ARE APPROXIMATE.
2. LONGITUDINAL REINFORCING NOT SHOWN FOR CLARITY.
3. FORMED OR CUT CONTRACTION JOINTS SHALL BE CREATED AT EACH PLACE WHERE THE BARRIER SHAPE CHANGES, TO MATCH ADJACENT PAVEMENT JOINT SPACING, OR AT A MAXIMUM SPACING OF 6000 mm.
4. ALL DIMENSIONS ARE IN MILLIMETRES UNLESS OTHERWISE INDICATED.
5. THE ORIGINAL SEALED AND SIGNED DRAWING IS IN TRAFFIC ENGINEERING.
6. ALL REINFORCING SHALL HAVE MINIMUM 75 mm COVER, UNLESS OTHERWISE NOTED.
7. CONCRETE: CSA A23.1, EXPOSURE CLASS C-1, AIR CONTENT CATEGORY 1, COMPRESSIVE STRENGTH: BARRIER ≥ 45 MPA AND FOOTING ≥ 35 MPA, AT 28 DAYS.
8. SEE SHEET 5 FOR REINFORCING DETAILS.
9. TRANSVERSE REINFORCING NOT SHOWN FOR CLARITY.
10. SEE SECTIONS 'C-C' & 'D-D' FOR BELOW GRADE DESIGN OPTIONS.
11. NEW OR EXISTING REINFORCED CONCRETE FOOTING: CSA A23.1, EXPOSURE CLASS C-1, AIR CONTENT CATEGORY 1, COMPRESSIVE STRENGTH ≥ 35 MPa, AT 28 DAYS.
12. END SECTION SPACING MUST CONTINUE INTO ADJACENT SECTION(S) OF BARRIER AS NECESSARY.

REVISIONS		
DATE	DESCRIPTION	BY



**MANITOBA**  
CONSTRAINED WIDTH  
CONSTANT SLOPE  
BARRIER - ROADSIDE  
TL-5 TO TL-4 TRANSITION  
(1250 TO 915)

SHEET NO: 3 OF 5	DATE: 2020 - 11
DESIGNED BY:	H. LARSEN
DRAWN BY:	L. LIEBRECHT
REVIEWED BY:	N. JOYAL
<b>TSTG97e</b>	

**SECTION 'C-C'**  
END SECTION, OPTION 1  
SCALE 1:20

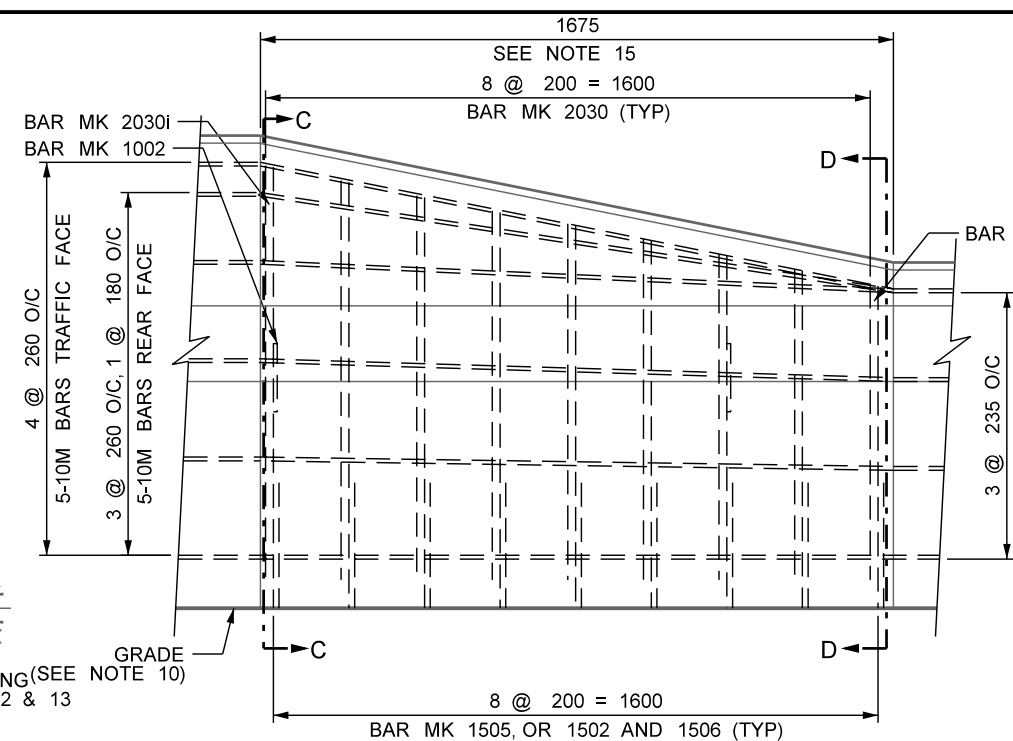
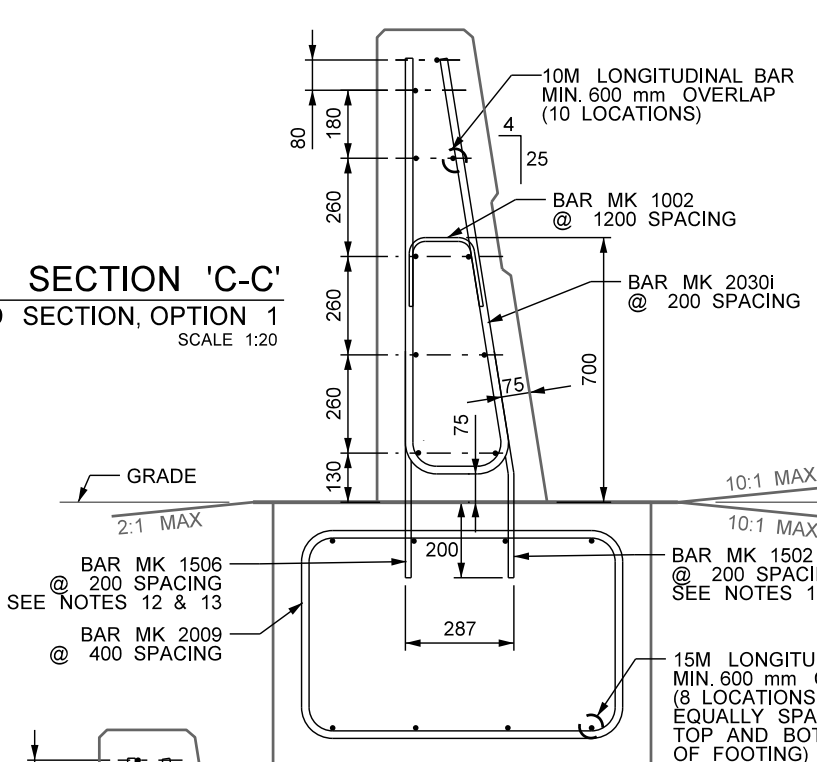

**SECTION 'D-D'**  
END SECTION, OPTION 1  
SCALE 1:20

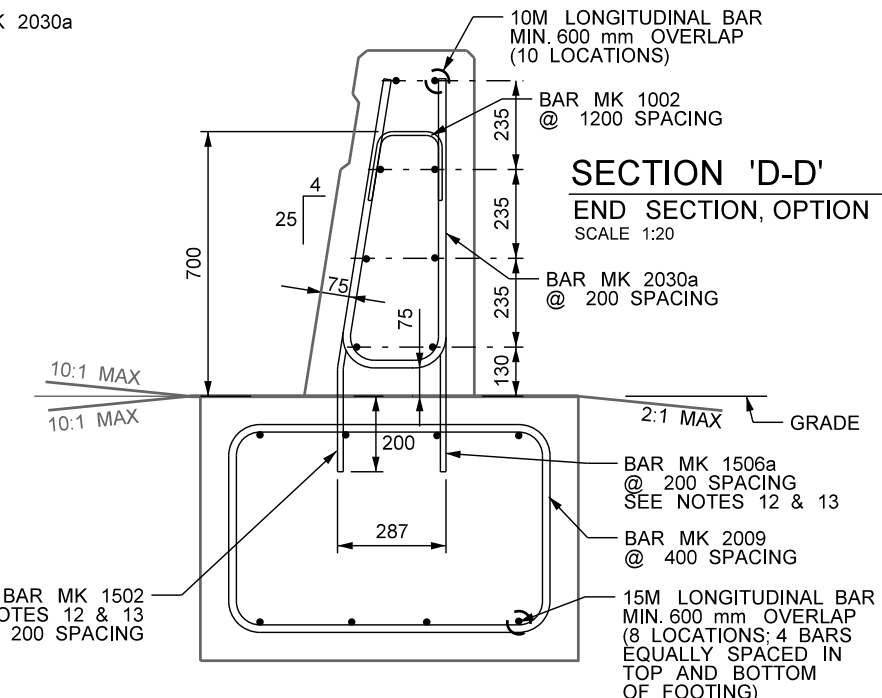

**ELEVATION**  
SCALE 1:20

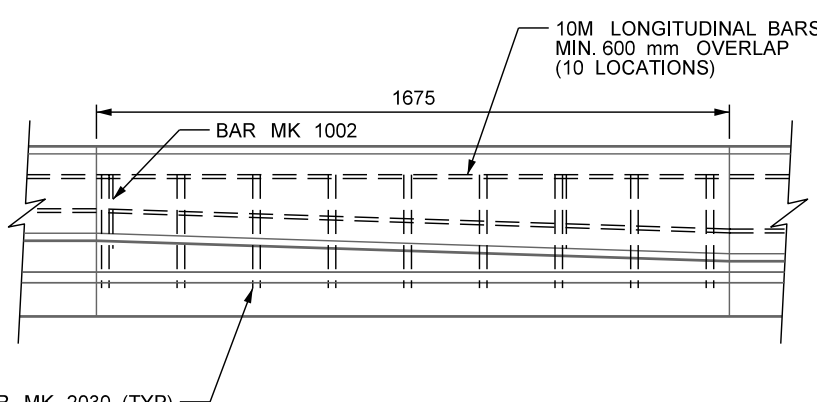

**PLAN**  
SCALE 1:20  
**END SECTION DETAILS**

**SECTION 'D-D'**  
END SECTION, OPTION 2  
SCALE 1:20

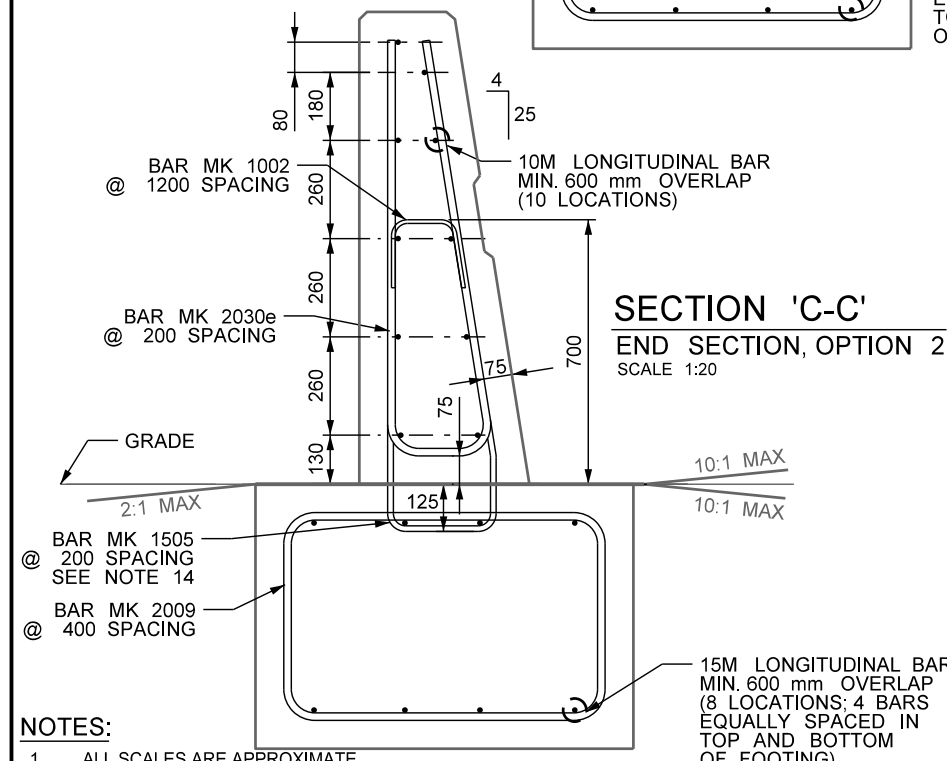
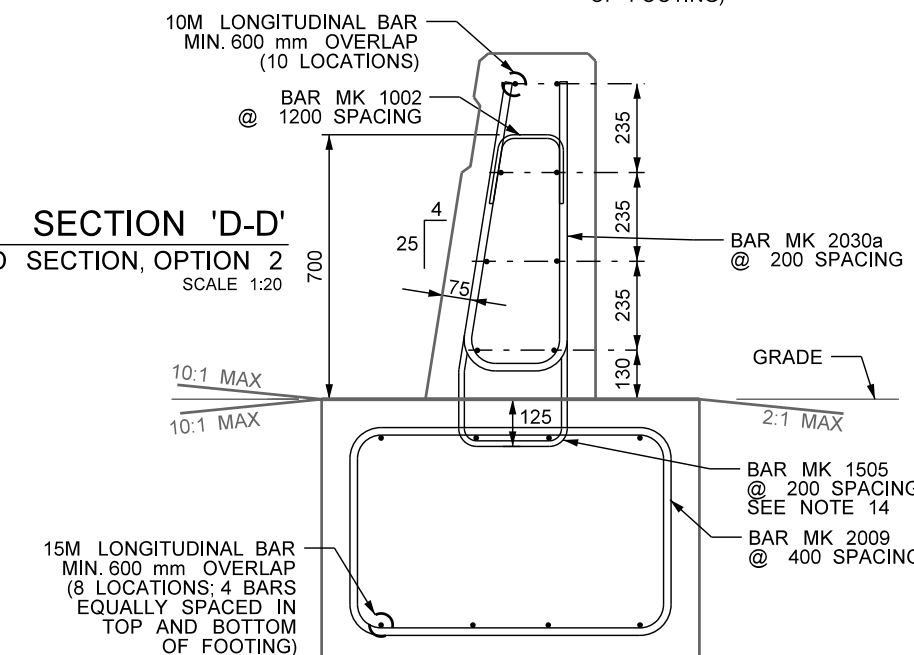

- NOTES:**
- ALL SCALES ARE APPROXIMATE.
  - LONGITUDINAL REINFORCING NOT SHOWN FOR CLARITY.
  - FORMED OR CUT CONTRACTION JOINTS SHALL BE CREATED AT EACH PLACE WHERE THE BARRIER SHAPE CHANGES, TO MATCH ADJACENT PAVEMENT JOINT SPACING, OR AT A MAXIMUM SPACING OF 6000 mm.
  - ALL DIMENSIONS ARE IN MILLIMETRES UNLESS OTHERWISE INDICATED.
  - THE ORIGINAL SEALED AND SIGNED DRAWING IS IN TRAFFIC ENGINEERING.
  - ALL REINFORCING SHALL HAVE MINIMUM 75 mm COVER, UNLESS OTHERWISE NOTED.
  - CONCRETE: CSA A23.1, EXPOSURE CLASS C-1, AIR CONTENT CATEGORY 1, COMPRESSIVE STRENGTH: BARRIER ≥ 45 MPA AND FOOTING ≥ 35 MPA, AT 28 DAYS.
  - SEE SHEET 5 FOR REINFORCING DETAILS.
  - TRANSVERSE REINFORCING NOT SHOWN FOR CLARITY.
  - SEE SECTIONS 'C-C' & 'D-D' FOR BELOW GRADE DESIGN OPTIONS.
  - NEW OR EXISTING REINFORCED CONCRETE FOOTING: CSA A23.1, EXPOSURE CLASS C-1, AIR CONTENT CATEGORY 1, COMPRESSIVE STRENGTH ≥ 35 MPa, AT 28 DAYS.
  - HOLES IN FOOTING SHALL BE DRILLED VERTICALLY 2 mm LARGER THAN REINFORCING.
  - HOLES IN FOOTING SHALL BE PREPARED FOR EPOXY (HILTI HIT RE 500, OR APPROVED ALTERNATIVE) AS DIRECTED BY MANUFACTURER.
  - STIRRUP SHALL BE SECURELY ATTACHED TO REBAR.
  - END SECTION SPACING MUST CONTINUE INTO ADJACENT SECTION(S) OF BARRIER AS NECESSARY.

REVISIONS		
DATE	DESCRIPTION	BY



**MANITOBA**  
CONSTRAINED WIDTH  
CONSTANT SLOPE  
BARRIER - ROADSIDE  
TL-5 TO TL-4 TRANSITION  
(1250 TO 915)

SHEET NO: 4 OF 5	DATE: 2020 - 11
DESIGNED BY:	H. LARSEN
DRAWN BY:	L. LIEBRECHT
REVIEWED BY:	N. JOYAL
<b>TSTG97e</b>	

MARK	TYPE	PIN DIAMETER (mm)	TOTAL LENGTH (mm)	MASS			BENDING DIAGRAM
				kg	kg/m		
					INTERIOR SEC.	END SEC.	
1002	BENT	65	503	0.39	0.33	0.33	
1502	BENT	65	604	0.95	2.38	4.75	
1505	BENT	65	1300	2.04	5.10	10.20	
1506	STR	0	600	0.94	2.35	4.70	
2008	BENT	125	2885	6.79	16.98	---	
2009	BENT	125	3283	7.73	---	38.65	
							DIMENSION
2030a	BENT	125	1760	4.15	2.48	2.48	
2030b	BENT	125	1840	4.33	---	2.59	
2030c	BENT	125	1921	4.52	2.70	2.70	
2030d	BENT	125	2002	4.71	---	2.81	
2030e	BENT	125	2102	4.95	2.96	2.96	
2030f	BENT	125	2163	5.09	---	3.04	
2030g	BENT	125	2243	5.28	3.15	3.15	
2030h	BENT	125	2324	5.47	---	3.27	
2030i	BENT	125	2403	5.65	3.38	3.38	
LONGITUDINAL REINFORCING - MASS (kg/m)							
BAR	INTERIOR SECTION	END SECTION	FOOTING				
			OPTION 1	OPTION 2	OPTION 3		
10M	8.24	8.24	---	---	---		
15M	---	---	13.19	13.19	---		
20M	---	---	---	---	---		

**NOTES:**

- ALL DIMENSIONS GIVEN IN BENDING DIAGRAM ARE OUT TO OUT, EXCEPT RADII AND EXTENSIONS ON 90°, 135° & 180° HOOKS. EXTENSIONS ON 90°, 135° & 180° HOOKS ARE THE "A" OR "G" DIMENSIONS FOR THE STANDARD 90°, 135° & 180° HOOKS REFERENCED FROM THE RSIC "MANUAL OF STANDARD PRACTICE". RADII ARE INSIDE DIMENSIONS. ALL REINFORCING STEEL BENDS AND HOOKS SHALL CONFORM TO CLAUSE 6.6.2 OF CSA A23.1 UNLESS NOTED OTHERWISE IN THE BILL OF REINFORCING STEEL.
- ALL REINFORCING STEEL SHALL BE DEFORMED STEEL UNLESS NOTED OTHERWISE IN THE BILL OF REINFORCING STEEL.
- ALL REINFORCING STEEL SHALL CONFORM TO CSA G30.18-M92 "BILLET STEEL BARS FOR CONCRETE REINFORCEMENT" GRADE 400W, UNLESS NOTED OTHERWISE IN THE BILL OF REINFORCING STEEL.
- LIKE BARS SHALL BE BUNDLED, SECURELY TIED, AND IDENTIFIED AS TO MARK No. BY APPROPRIATE MEANS. ALL OTHER ITEMS TO BE IDENTIFIED IN A SIMILAR FASHION.
- BARS MARKED WITH THE SUFFIX "P" SHALL BE PLAIN UNDEFORMED BARS IN ACCORDANCE WITH CAN/CSA G40.21-M92 GRADE 300W.
- ALL BARS SHALL BE BENT IN ACCORDANCE WITH THE FOLLOWING DETAIL:

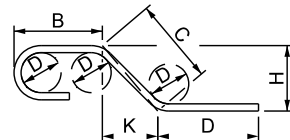

REVISIONS		
DATE	DESCRIPTION	BY



**MANITOBA**  
**CONSTRAINED WIDTH**  
**CONSTANT SLOPE**  
**BARRIER - ROADSIDE**  
**TL-5 TO TL-4 TRANSITION**  
**(1250 TO 915)**

SHEET NO: 5 OF 5	DATE: 2020 - 11
DESIGNED BY: H. LARSEN	
DRAWN BY: L. LIEBRECHT	
REVIEWED BY: N. JOYAL	

**TSTG97e**