

X-TENUATOR® SYSTEM

NCHRP 350 TL-3 Redirective, Non-Gating Impact Attenuator



BARRIER SYSTEMS®

BY LINDSAY



Installation and Maintenance
Manual Supplement

X-TENUATOR®

Redirective, Non-Gating, Crash Cushion

Preface ----- 3

System Overview ----- 3

Before Installation ----- 3

Limitations and Warnings ----- 3

Required Tools ----- 4

Limited Warranty ----- 5

Parts Identification ----- 6

Part 1 - Position System Components ----- 9

Part 2 - Install Wire Tethers and Blockouts ----- 11

Part 3 - Install Back Panels ----- 12

Part 4 - Install Front Panels ----- 14

Part 5 - Install Head Unit and Support Legs ----- 17

Part 6 - Anchor System to Foundation ----- 20

Part 7 - Install Cables ----- 23

Part 8 - Tighten Cables ----- 25

Part 9 - Install Nose Cartridge ----- 26

Part 10 - Install Nose Cover ----- 27

Part 11 - Secure Wire Tethers on Blockouts ----- 28

Part 12 - Install Plastic Nut Protectors ----- 29

Part 13 - Install Transition Adapter Bracket ----- 30

Final Inspection ----- 31

APPENDICES

Appendix A - System Configuration Drawings ----- 32

Appendix B - Anchoring Foundation Options ----- 39

Appendix C - Transitions ----- 42

Preface

The X-TENUator Redirective Non-Gating Crash Cushion System incorporates the newest roadside safety materials and engineering processes.

As with any roadside safety device, the X-TENUator System must be installed properly to ensure optimum performance. Thoroughly review and fully understand the installation instructions and product limitations before starting the installation. Do not start the installation without the proper plans and tools required.

System Overview

The X-TENUator (X-TEN) is a fully re-directive non-gating crash cushion for shielding fixed roadside hazards. During head on impacts, the system gradually decelerates an errant vehicle and redirects the vehicle away from the hazard when impacted on the side. The system is comprised of an energy absorbing nose cover, dual X-Tension impact heads and friction cables, W-Beam side panels, specially designed posts, front cable anchors, and an independent rigid backstop. Standard W-Beam block-out spacers attach the side panels to the posts.

Before Installation

Placement and use of the X-TENUator System should be done in accordance with the guidelines and recommendations set forth in the "AASHTO Roadside Design Guide", FHWA memoranda and other state and local standards.

Depending on the application and circumstances at the site, installation and assembly of a TL-3 System should take an experienced two person crew with proper tools approximately two hours to complete.

The X-TENUator System is a highly engineered safety device made up of a relatively small number of parts. Before starting installation ensure that one is familiar with the make up of the system.

Limitations and Warnings

The X-TENUator System has been rigorously tested and evaluated per the recommendations in the National Highway Cooperative Research Program NCHRP Report 350 Guidelines for terminals and crash cushions. The impact conditions recommended in NCHRP 350 are intended to address typical in-service collisions.

When properly installed and maintained, the system is capable of stopping or containing and redirecting impacting vehicles in a predictable and safe manner under the NCHRP Report 350 impact conditions. Vehicle impacts that vary from the NCHRP Report 350 impact conditions described for redirective, non gating, crash cushions may result in significantly different results than those experienced in testing.

Vehicle impact characteristics different than or in excess of those encountered in NCHRP Report 350 testing (speed and angle) may result in system performance that may not meet the NCHRP Report 350 evaluation criteria.

If you need additional information, or have questions about the X-TENUator System, please call the Lindsay Transportation Solutions Customer Service Department at (888) 800-3691 (U.S. toll free) or +1 (707) 374-6800.

Required Tools

- Tape Measure
- Pry Bar
- Large Pry Bar (60" [152 cm] recommended)
- Vice Grips or Clamps
- Ratchet Strap / Comealong
- Torque Wrench (5 FT-LBS and 120 FT-LBS Capacity)
- Crescent Wrench
- Wrenches
 1. 7/16" [10 mm]
 2. 3/4" [19 mm]
 3. 9/16" [13 mm]
 4. 15/16" [22 mm]
 5. 1 1/8" [27 mm]
- Ratchets
 1. 1/2" [13 mm]
 2. 3/4" [19 mm]
- Sockets
 1. 7/16" [10 mm]
 2. 3/4" [19 mm]
 3. 9/16" [13 mm]
 4. 15/16" [22 mm]
 5. 1 1/8" [27 mm]
- Extensions
- Rotohammer or Cord Drill for drilling holes in concrete or asphalt
- Bit for drilling holes
 - 7/8" [22 mm] x 10" [254 mm] - Concrete
 - 7/8" [22 mm] x 20" [508 mm] - Asphalt)
- Air Impact Wrench (Recommended/Optional)



Note: The tools list is a general recommendation. Depending on the specific characteristics of the job site, more or less tools may be necessary.



STANDARD LIMITED WARRANTY

Lindsay Transportation Solutions, Inc. "LTS" (formerly Barrier Systems) has tested the impact performance of its barriers and crash cushion systems, and other highway safety hardware under controlled conditions, however, LTS does not represent nor warrant that the results of those controlled conditions would necessarily avoid injury to persons or property. LTS EXPRESSLY DISCLAIMS ANY WARRANTY OR LIABILITY FOR CLAIMS ARISING BY REASONS OF DEATH OR PERSONAL INJURY OR DAMAGE TO PROPERTY RESULTING FROM ANY IMPACT, COLLISION OR HARMFUL CONTACT WITH THE PRODUCTS OR NEARBY HAZARDS OR OBJECTS BY ANY VEHICLE, OBJECTS OR PERSONS.

LTS warrants that any product or component part manufactured by LTS will be free from defects in material or workmanship. LTS will replace free of cost any Product or component part manufactured by LTS that contains such a defect.

THE FOREGOING WARRANTY IS IN LIEU OF AND EXCLUDES ALL OTHER WARRANTIES NOT EXPRESSLY SET FORTH HEREIN, WHETHER EXPRESS OR IMPLIED BY OPERATION OF LAW OR OTHERWISE, INCLUDING BUT NOT LIMITED TO ANY IMPLIED WARRANTIES OF MERCHANTABILITY OR FITNESS FOR A PARTICULAR PURPOSE.

LTS' LIABILITY UNDER THIS WARRANTY IS EXPRESSLY LIMITED TO REPLACEMENT FREE OF COST (IN THE FORM AND UNDER THE TERMS ORIGINALLY SHIPPED), OR TO REPAIR OR TO MANUFACTURE BY LTS, PRODUCTS OR PARTS NOT COMPLYING WITH LTS SPECIFICATIONS, OR, AT LTS' ELECTION, TO THE REPAYMENT OF AN AMOUNT EQUAL TO THE PURCHASE PRICE OF SUCH PRODUCTS OR PARTS, WHETHER SUCH CLAIMS ARE FOR BREACH OF WARRANTY OR NEGLIGENCE. LTS SHALL NOT BE LIABLE FOR ANY INCIDENTAL, CONSEQUENTIAL OR SPECIAL LOSSES, DAMAGES OR EXPENSES OF ANY KIND, INCLUDING, WITHOUT LIMITATION, ANY SUCH LOSSES, DAMAGES OR EXPENSES ARISING DIRECTLY OR INDIRECTLY FROM THE SALE, HANDLING OR USE OF THE PRODUCTS FROM ANY OTHER CAUSE RELATING THERETO, OR FROM PERSONAL INJURY OR LOSS OF PROFIT.

Any claim by the Buyer with reference to Products sold hereunder for any cause shall be deemed waived by the Buyer unless LTS is notified in writing, in the case of defects apparent on visual inspection, within ninety (90) days from the delivery date, or, in the case of defects not apparent on visual inspection, within twelve (12) months from the said delivery date. Products claimed to be defective may be returned prepaid to LTS' plant for inspection in accordance with return shipping instructions that LTS shall furnish to the Buyer forthwith upon receipt of the Buyer's notice of claim. If the claim is established, LTS will reimburse that Buyer for all carriage costs incurred hereunder.

The forgoing warranty benefits shall not apply to (i) any Products that have been subject to improper storage, accident, misuse or unauthorized alterations, or that have not been installed, operated and maintained in accordance with approved procedures and (ii) any components manufactured by the Buyer.



Parts Identification



**Nose Cover
B100238**



**Nose Cartridge
B100239**

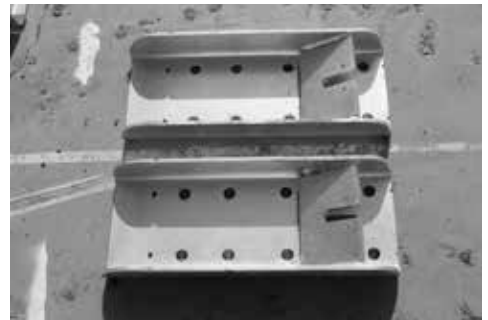

**(2) Cable Anchor
B100244**



**(2) Head Unit
B061072**



**(5) Posts
B100254**



**(2) Backstop Weldment
(Right B100266 and Left B100267)**



**(2) Back Panels B100263
(2) Front Panels B100259**



**(10) Composite Blockout
B090534**



**Wire Tether and Clamp Kit
K100201**



**(2) Cable Friction Plate
B100348**

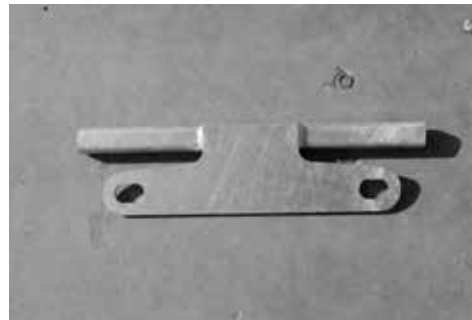

**Upper Head Support
B100247**

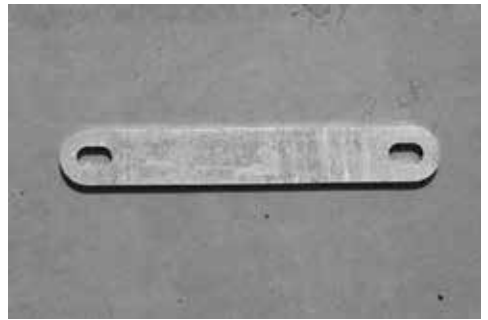

**Lower Head Support
B100250**

Parts Identification

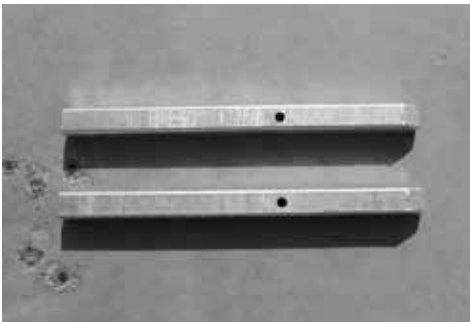

**(2) Head Support Leg
B100251**



**(2) Slider Brace
B100346**



**(1) Backstop Brace
B100280**



**(2) Cable
B100281**

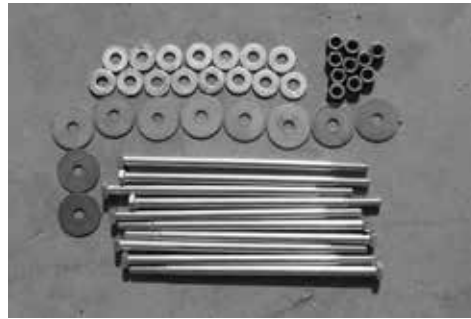

**Guardrail Panel Hardware
3/8" [10 mm]**



**Shear Bolt Kit
K080123**

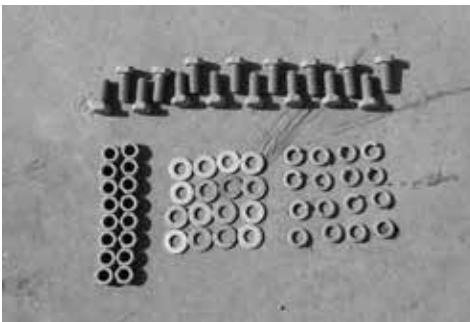

**Slider Brace Hardware
1/2" [13 mm]**



**Head Unit Hardware
5/8" [16 mm]**



**Upper and Lower Head Unit Support
and Backstop Hardware 3/4" [19 mm]**



**Head Support Leg Hardware
3/4" [19 mm]**

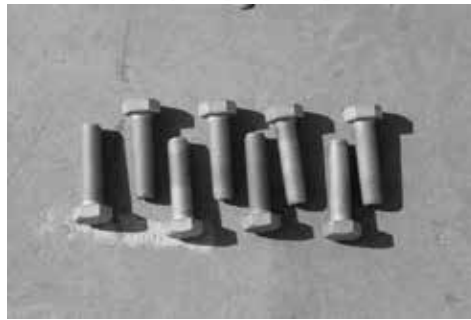

Friction Plate Hardware M20



**Nose Cartridge and Nose Cover
Hardware 1/4" [7 mm]**

Parts Identification

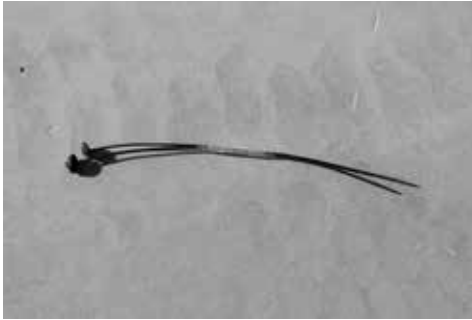

**(2) Cable Tie
4002138**

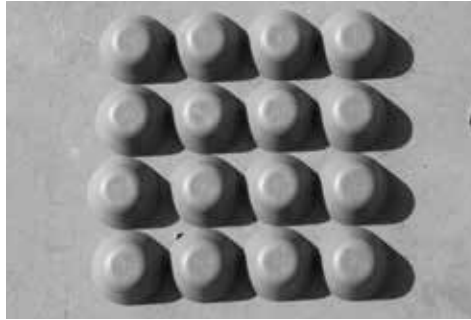

**(16) Plastic Nut Protector
B080755**

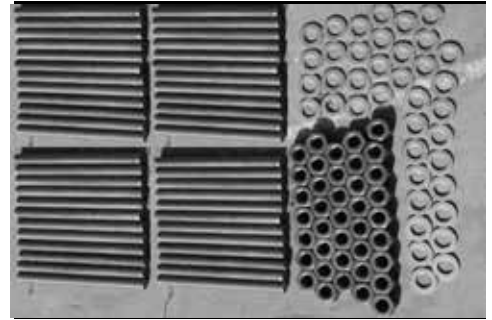

Foundation Anchoring Hardware 3/4
(42) - Asphalt BSI-1007014-KT
(26) Concrete BSI-1007015-KT
(not shown)



**Transition Adapter Bracket
BSI-1007020-KT**

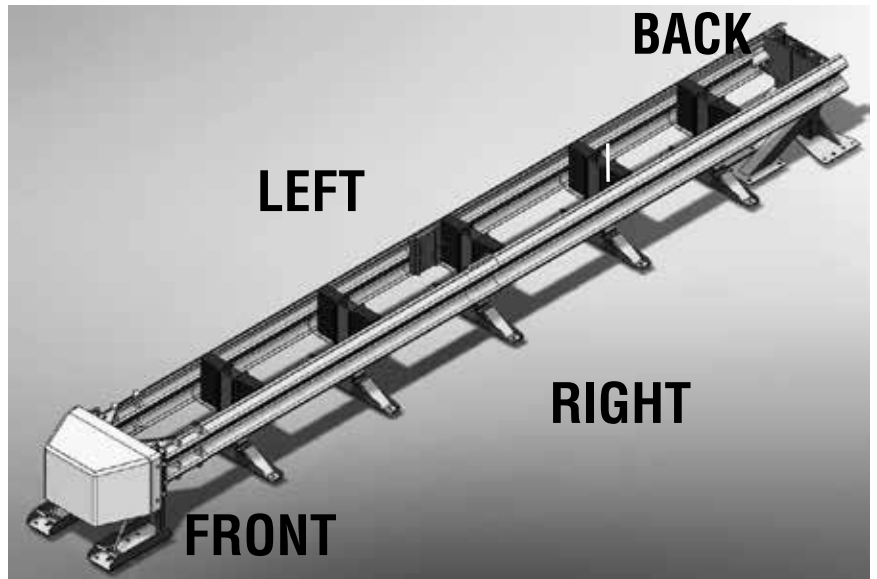

The picture of the X-TENUATOR System above illustrates how the System is referred to throughout this manual.

Step 1 - Position System Components

Components Required:

- (2) Backstop Weldment (Right and Left) - B100266, B100267
- (5) Posts - B100254
- (2) Cable Anchor - B100244
- (1) Backstop Brace - B100280

Hardware Required:

- (4) 3/4" x 2 1/4" [19 x 57 mm] Bolt
- (8) 3/4" [19 mm] Washer
- (4) 3/4" [19 mm] Nut

1a. The backstop is made up of two components, a right and a left weldment. Begin positioning the system components by first positioning the backstop weldments at the approximate desired location.

1b. Once the backstop is in its desired approximate location install the backstop brace to the left and right components of the backstop using four (4) 3/4" x 2 1/4" [19 x 57 mm] bolts.

The bolts should be installed with the bolt head on the outside and the nut on the inside of the backstop weldment.

Note: If using a transition, install transition adapter bracket in place of backstop brace. Refer to section titled "Install Transition Adapter Bracket," Page 30.

DO NOT TIGHTEN HARDWARE AT THIS TIME; ALL HARDWARE WILL BE TIGHTENED AT A LATER STEP.

Notes:



1c. Starting at the back of the system begin to position the posts at their approximate locations. Refer to Appendix A or B for layout dimensions, page 34 or 40.

1d. Next, position the two front cable anchors at their approximate location.



Note: Special attention must be taken when positioning the posts. The bottom plate of the posts is bent up on the back and front of the post. The front of the post has a shorter bend and the anchor holes are exposed. This side should be facing the front of the system.



Step 2 - Install Wire Tethers and Blockouts

Components Required:

- (5) Wire Tether & Clamps - K100201
- (10) Composite Blockout - B090534

Notes:

2a. Guide wire tethers through all five (5) posts. The posts have two (2) holes drilled on each side; guide the wire tether through the front holes.



2b. Next, install two (2) blockouts on each post, one (1) on each side. At each post, guide the wire tether through the front hole of each blockout.



Step 3 - Install Back Panels

Components Required:

- (2) Back Panel Weldment - B100263
- (8) Shear Bolts - K080123

Hardware Required:

- (6) 3/8" x 9" [10 x 230 mm] Bolt
- (6) 3/8" [10 mm] Washer (Big),
- (6) 3/8" [10 mm] Washer (Small)
- (6) 3/8" [10 mm] Nut

3a. Install the two back panels first. The back panel can be identified by the panel that has an angle iron welded to one end of the panel. The shear bolts are used to attach the panels at the backstop and the 3/8" [10 mm] bolts are used at the posts. Start by holding the panel in place and align the holes at the backstop to enable the installation of at least one (1) shear bolt. Once at least one (1) shear bolt is in place the panel will hold in place at the back of the system. The person at the back of the system can now move toward the end of the panel and install the 3/8" [10 mm] bolt to hold the panel to the post.

3b. The panel is now in place, finish by installing the remainder of the guardrail bolts and shear bolts to secure the panel to the backstop and the posts.

Notes:



Note: When bolting on the panel at the posts, make sure that the wire tether does not get stuck between the blockout and the panel. Make sure that the wire tether is positioned inside the notch on the blockout which allows the wire tether to move freely once the panel is installed.



3c. Repeat the above steps for the other back panel on the opposite side of the system.

DO NOT TIGHTEN THE HARDWARE AT THIS TIME;
ALL HARDWARE WILL BE TIGHTENED AT A LATER
STEP.



Tip: Assemble the 3/8" [10 mm] bolts with washers and nuts. Position the assembled bolts at each leg and the shear bolts at the backstop prior to positioning the panel in place so that the hardware is easily assessable when ready to bolt on the panel.

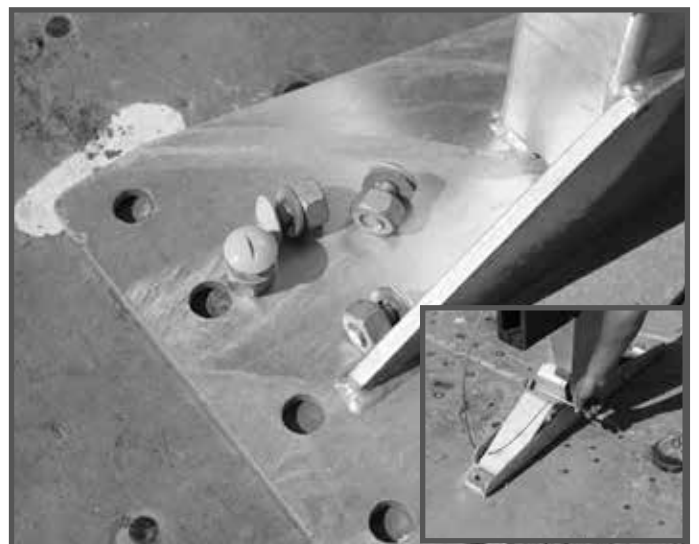

Step 4 - Install Front Panels

Components Required:

- (2) Front Panel - B100259
- (2) Slider Brace - B100346

Hardware Required:

- (16) 1/2" x 1 1/4" [13 X 32 mm] Bolt
- (16) 1/2" [13 mm] Washer
- (16) 1/2" [13 mm] Lock Washer
- (16) 1/2" [13 mm] Nut
- (4) 3/8" x 9" [10 x 230 mm] Bolt
- (4) 3/8" [10 mm] Washer (Big)
- (4) 3/8" [10 mm] Washer (Small)

4a. The 1/2" x 1 1/4" [13 x 32 mm] bolts are used to attach the slider brace to the panel and the 3/8" x 9" [10 x 230 mm] bolts are used at the posts. Position the front panel in place by slightly overlapping the back panel. Once overlapped, install the slider brace to the front panel keeping the panels overlapped at all times using only four (4) 1/2" [13 mm] bolts at this time; two (2) on the top and two (2) at the bottom.

The bolts should be installed from the outside in with the nuts on the inside of the system.

Note: Do not tighten the bolts at this time. If needed, use vice grips or clamps to hold the slider brace in place while installing the bolts.

Note: The slider brace should be installed with thick portion of slider brace pointing towards the back of System. **The System will not perform as designed if installed incorrectly.**

Note: When installing the slider brace it is easy to get the wire tether of post THREE stuck between the panel and slider brace. Make sure the wire tether is in the notch on the blackout and away from slider brace before attaching.

Notes:



- 4b. Once the slider brace is installed move toward the front and attach the panel to the first post using the 3/8" [10 mm] bolt; finish attaching the panel to the remaining post.



- 4c. The front panel is now in place; return to the slider brace and finish installing the rest of the bolts on the slider brace and panel. At this point tighten all eight (8) bolts that attach the slider brace to the panel.



- 4d. Repeat the above steps for the other front panel on the opposite side of the system.

Tip: Assemble the 3/8" [10 mm] bolts with washers and nuts and position the assembled bolts at each leg and the slider brace and 1/2" [13 mm] bolts, washer and nuts at post THREE prior to positioning the panel in place so that the hardware and slider brace are easily assessable when ready to bolt on the panel and slider brace.



Note: The only hardware that should be tightened at this point is Slider Brace hardware. ALL OTHER HARDWARE WILL BE TIGHTENED AT A LATER STEP.
Note: When installing SECOND front panel it may be necessary to use a ratchet strap to pull panels together for the 3/8" [10 mm] bolt to go through panel, blockout and post TWO.



4e. Once both front panels are installed, pull/tug on both panels to make sure the panels are fully extended so that the slider brace is against the angle iron on the back panel; they should be touching.



5d. Once the support leg is installed it is necessary to align the front of the leg with the notch located on the front cable anchor as shown and clamp together to hold in place. This allows for correct positioning of the cable anchor with the support leg when anchoring it to the foundation.



5e. Next, install the upper head support on the top portion of the head unit.



5f. Repeat the above steps to install the second portion of the head unit and the head support leg.



5g. Once the full head unit is installed, use the $\frac{3}{4}$ " x $2\frac{1}{2}$ " [19 x 64 mm] bolts with shoulder to secure the upper head support to the head unit. Next, install the lower head support using the $\frac{3}{4}$ " x $2\frac{1}{4}$ " [19 x 57 mm] bolts.

DO NOT TIGHTEN THE BOLTS AT THIS TIME.



Step 6 - Anchor System to Foundation

Components Required:

- Entire System (Already Assembled),
- Epoxy
- Epoxy Gun

Hardware Required:

- (26 – Concrete, 42 – Asphalt) $\frac{3}{4}$ " x 8" [19 x 203 mm] or $\frac{3}{4}$ " x 18" [19 x 457 mm] Anchor
- (26 – Concrete, 42 – Asphalt) $\frac{3}{4}$ " [19 mm] Washer
- (26 – Concrete, 42 – Asphalt) $\frac{3}{4}$ " [19 mm] Nut

6a. Re-align the system to make sure the anchor plates, posts, and backstop are all in the correct/final positions. Use Appendix A & B for layout dimensions and foundation requirements, page 34 and 40.

6b. Begin at the front of the system and work your way to the back, aligning the system to its final position. The first post must be in its correct position to ensure the system is square. Ensure the distance from the outside to outside of the head unit is 33 1/4" [84.5 cm]

6c. After the system has been aligned, **ALL HARDWARE SHOULD BE TIGHTENED AT THIS TIME. WHEN TIGHTENING THE YELLOW SHEAR BOLTS, DO NOT OVER-TIGHTEN. THE SHEAR BOLTS WILL BREAK IF OVER-TIGHTENED. DO NOT USE AN AIR-IMPACT WRENCH WHEN TIGHTENING THE SHEAR-BOLTS.** Once all the hardware is tightened, re-check all dimensions and placement of the anchor plates, posts, and backstop to make sure they are correct.

Notes:



6d. Begin to drill all required holes for installation.
Use parts as a drill guide.

Holes should be 7/8" (22 mm) diameter and drilled to;

- 6" (150 mm) – Concrete
- 16" (406 mm) – Asphalt



Note: NOT ALL HOLES ARE REQUIRED FOR A CONCRETE INSTALLATION. The holes identified with a notch are the required anchor points for a concrete installation. Refer to Appendix B, page 40.

For a concrete installation the required anchors points are as follows:

- Anchor Plate – (4) four anchors each anchor plate
- Posts – (2) two anchors each post
- Backstop – (4) four anchors for each backstop weldment (Left and Right)

For an asphalt installation all anchor points are required.



	Number of Anchors	
	Concrete Installation	Asphalt Installation
Anchor Plate (2)	4	8
Posts (5)	2	2
Backstop (2)	4	8
Total	26	42

6e. Once the holes are drilled ensure that they are fully cleaned and free of debris in accordance with the anchoring compound manufacturer's requirements. Failure to do this can result in the anchoring compound not adhering properly leading to a reduction in pullout capacity and possibility of failure of the system upon impact.

6f. Allow anchoring compound to cure before tightening anchors. Once compound has set, torque the anchors to the appropriate requirements.

Torque specifications are as follows:

- **CONCRETE – 120 ft-lbf [160 N-m].**
- **ASPHALT – 5 ft-lbf [8 N-m]**

ANCHORING REQUIREMENTS

Speed Set 2 Anchoring Compound is supplied with the System. Alternate anchoring compounds may be used if the following specification is met:

Minimum 18,000 lbf [80 kN] ultimate load in tension (pullout) and a shear of 22,000 lbf [98 kN] in 4,000 PSI concrete.

Products such as HILTI HIT HY150 injection Adhesive Anchor, RE500 injection Adhesive Anchor or HVA Adhesive Anchoring System fit these criteria. Refer to Table 1 below for required hole size for recommended anchor compounds.

Mechanical / Removable Anchors

When standard chemical anchors cannot be used to secure Barrier System products as a result of state, local, site or other requirements, mechanical anchors may be used in concrete applications. Various mechanical anchors are available that use wedge, self-undercutting, or expansion coils to establish the locking bond with the concrete. A minimum of 18,000 lbf [80kN] ultimate load in the tension (pull out) and a shear of 22,000 lbf [98kN] is required for use with BSI products in 4,000 PSI concrete. One product recommended is the HILTI HCA item number 00252018 HCA 3/4" x 6".

IMPORTANT: FOLLOW MANUFACTURER'S SPECIFICATIONS FOR HOLE SIZE AND PREPARATION

Anchoring Compound	Hole Diameter
US Anchor Ultra Bond Speed Set	7/8" [22 mm]
HILTI - HIT HY 150	13/16" [20.5mm]
HILTI - HVA Adhesive Anchor System	7/8" [22 mm]
HILTI - RE 500	13/16" [20.5 mm] to 1" [25 mm]

Step 7 - Install Cables

Components Required:

- (2) Cable - B100281
- (2) Cable Friction Plate - B100348

Hardware Required:

- (2) Cable Tie - 4002138

7a. Begin by installing the cable friction plate inside the cable locking plates located behind the head unit. Unwind the cable and remove the nut from the back end of the cable. There may be a washer pre-installed with the nut; if there is a washer, remove the washer as well. Guide the cable through top hole of the head unit and the bottom hole of the friction plate and guide it through the entire length of the system to the backstop. At the backstop re-install the nut on the cable, but do not tighten.

DO NOT use the washer that was previously removed; the washer may be discarded.

Note: If you removed a washer from the back end of the cable, do not re-install the washer. The washer may be discarded.

Notes:



- 7b. At the front of the system, attach the cable to the cable anchor through the slot on the anchor. The nut on the cable should be flush with the threaded end of the cable at this time.

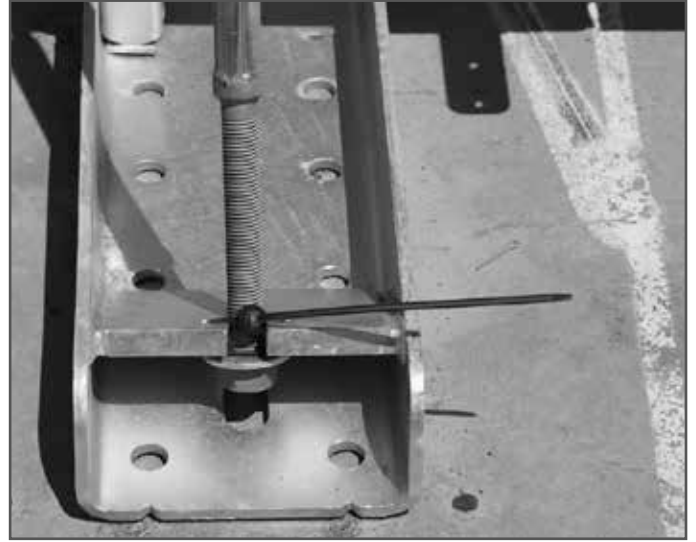

- 7c. Install the cable tie on the cable anchor to help keep the cable in place.

Note: Failure to install cable tie could result in injury when tightening cables.

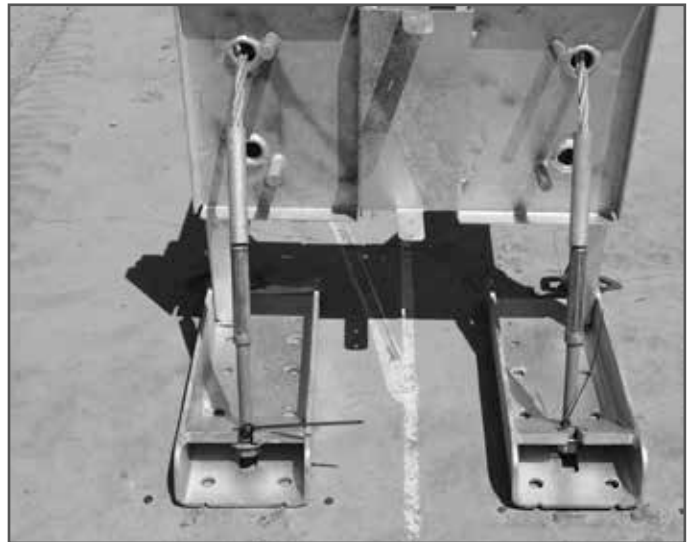

- 7d. Repeat the above steps to install the second cable on the opposite side of the system.

Step 8 - Tighten Cables

Components Required:

- Components already installed

Hardware Required:

- (8) M20 -2.5 x 75 mm Bolt

8a. Install (4) four friction head bolts on the head unit. Begin to turn the friction plate using a large pry bar. While turning the friction plate, alternate tightening the bolts to ease the rotation of the friction plate. The edges of the friction plate should be touching the flat areas of the cable locking plates. A depiction of this can be found in Appendix A, page 35.

Tip: It is recommended that an air impact tool be used.

8b. Once the plate has been turned and secured with the bolts, tighten the cable nut at the cable anchor.

8c. At the back of the system, the backstop, remove the slack in the cable by tightening the nut on the cable at this location. **THERE ARE NO TORQUE REQUIREMENTS FOR THE TIGHTENING OF THE CABLE.**

Repeat the above steps for the cable on the opposite side of the system.

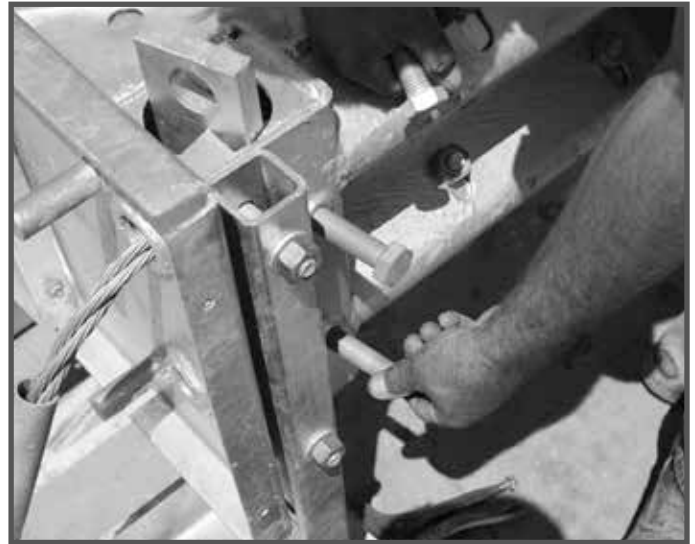

Step 9 - Install Nose Cartridge

Components Required:

- Nose Cartridge - B100239

Hardware Required:

- (4) 1/4" x 1" [7 X 25 mm] Bolt
- (8) 1/4" [7 mm] Washer
- (4) 1/4" [7 mm] Nut

Install the nose cartridge to the head unit using the 1/4" x 1" [7 x 25 mm] bolts. Completely tighten all the bolts.

Notes:



Step 10 - Install Nose Cover

Components Required:

- Nose Cover

Hardware Required:

- (4) ¼" x 1" [7 x 25 mm] Bolt
- (4) ¼" [7 mm] x 1.0 Washer
- (4) ¼" [7 mm] Washer
- (4) ¼" [7 mm] Nut

Install the nose cover over the nose cartridge and secure it using the ¼" x 1" [7 x 25 mm] bolts.

Notes:



Step 11 - Secure Wire Tethers on Blockouts

Components Required:

- (5) Wire Tethers (Already installed in a previous step)

Hardware Required:

- (10) Wire Rope Clamp

Secure the wire tethers around the posts and blockouts using two (2) wire rope clamps per tether. For correct orientation of the clamp place the u-bolt on the side of the cut end of the wire rope. Install the wire rope clamps as specified in Appendix A.

Notes:



Step 12 - Install Plastic Nut Protectors

Components Required:

- Already assembled

Hardware Required:

- (16) Plastic Nut Protectors - B080755

Notes:

Install the plastic nut protectors over the exposed nuts at the front of the system. The nut protectors are installed by screwing the protector over the exposed nut and bolt threads.

INSTALLATION IS NOW COMPLETE. MAKE A FINAL INSPECTION TO BE SURE THAT ALL COMPONENTS ARE INSTALLED CORRECTLY AND THAT ALL HARDWARE IS TIGHTENED. ENSURE THAT THE TORQUE ON THE FOUNDATION ANCHORS IS IN ACCORDANCE TO THE SPECIFICATIONS IN THIS MANUAL.



Step 13 - Install Transition Adapter Bracket (Required Only When Using Transition)

Components Required:

- (1) Transition adapter bracket

Hardware Required:

- (6) 3/4" x 2 1/4" [19 x 57 mm] bolts
- (12) 3/4" [19 mm] Washers
- (6) 3/4" [19 mm] Nuts

When using a transition in conjunction with the X-TENUator System it is necessary to use a transition adapter bracket. The transition adapter bracket should be used in place of the backstop brace in Part 1, Step 2 of this manual.

Install bracket using six (6) 3/4 x 2 1/4" [19 x 57 mm] bolts.

Note: Failure to use the transition adapter bracket when using transition(s) may result in the system not functioning properly upon impact.

Note: When installing the transition panels or bridge shoes, install the first guardrail panel under the rear panel of the system. Overlap remaining panels according to the direction of traffic.

Notes:



Final Inspection Checklist

Inspection Date	Inspection By:	Item
		All foundation anchors are secured and torqued.
		System posts are facing forward.
		No washers on rear cable nuts.
		Friction plates turned completely. touching flat edges.
		All hardware completely tightened.

Appendix A - System Configuration

There is currently one model available for the X-TENUator System. The X-TENUator System has been tested per National Cooperative Highway Research Program 350 (NCHRP Report 350) Test Level 3 and accepted for use on the National Highway System (NHS) by the Federal Highway Administration.

The X-TENUator System is capable of shielding narrow hazards up to 21” [53 cm] in width. Wider hazards may be shielded with the use of additional standard guardrail components.

As with all crash cushions, the X-TENUator System requires appropriate clear zones in accordance with the “AASHTO Roadside Design Guide,” FHWA memoranda and other state and local standards.

Additionally, the X-TENUator System requires 12’ (3.66 m) in length directly behind the system adjacent to the hazard to allow the panels to slide backwards during an impact.

The system configuration and required clear zone are shown in the following drawings.

DRAWINGS

System Components DWG# XTEN100N	33
Bill Of Materials	37
Required Panel Clear Zone DWG# B100223	38

Appendix A - System Configuration

NOTES UNLESS OTHERWISE SPECIFIED:

- X-TENUATOR TO BE INSTALLED PER MANUFACTURER'S INSTRUCTIONS.
- ITEMS # 17, 42 & 43 NOT SHOWN.

Item	Qty	Description	Part #	U/N
1	1	Nose Cover, X-Tenuator	B100238	EACH
2	1	FA Nose, Cartridge, X-Tenuator	B100239	EACH
3	1	CHM Anchor, Weldment, 1/2" Dia	B100244	EACH
4	2	CHM Anchor, Weldment, 1/2" Dia	B100245	EACH
5	2	CHM Friction Pin, 1/2" Dia	B100246	EACH
6	1	Upper Head Support, Weldment, 1/2" Dia	B100247	EACH
7	1	Lower Head Support, Pipe, 1/2" Dia	B100250	EACH
8	2	Head Support, Leg, Weldment, 1/2" Dia	B100251	EACH
9	2	Head Support, Leg, Weldment, 1/2" Dia	B100252	EACH
10	10	W-Beam Composite Backstop, 8in, 1/2" Dia	B990534	EACH
11	2	Front Panel, Weldment, 1/2" Dia	B100259	EACH
12	2	Sliver Beeps, Weldment, Front, 1/2" Dia	B100346	EACH
13	2	Sliver Beeps, Weldment, Rear, 1/2" Dia	B100347	EACH
14	2	Backstop, Weldment, 8in, 1/2" Dia	B100263	EACH
15	1	Backstop, Weldment, Left, 1/2" Dia	B100267	EACH
16	1	Backstop, Weldment, Right, 1/2" Dia	B100268	EACH
17	2	CHM Assembly, X-Tenuator, 1/2" Dia	B100291	EACH
18	2	CHM Assembly, X-Tenuator, 1/2" Dia	B100292	EACH
19	10	C-Scr Nut, 1/2" Dia, 1.62" L, 6in, 1/2" Dia	2000238	EACH
20	6	Weldment, 1/2" Dia, 1.00" Dia, 0.53	2000263	EACH
21	14	Weldment, 1/2" Dia, 1.00" Dia, 0.53	2001446	EACH
22	10	Nut, 1/2" Dia, 1.62" L, 6in, 1/2" Dia	2000274	EACH
23	10	Nut, 1/2" Dia, 1.62" L, 6in, 1/2" Dia	2000275	EACH
24	8	Weldment, 1/2" Dia, 1.62" L, 6in, 1/2" Dia	2000118	EACH
25	4	Nut, 1/2" Dia, 1.62" L, 6in, 1/2" Dia	2000134	EACH
26	2	C-Scr Nut, 1/2" Dia, 1.62" L, 6in, 1/2" Dia	2001633	EACH
27	6	C-Scr Nut, 1/2" Dia, 1.62" L, 6in, 1/2" Dia	2000338	EACH
28	6	C-Scr Nut, 1/2" Dia, 1.62" L, 6in, 1/2" Dia	2000339	EACH
29	8	Nut, 1/2" Dia, 1.62" L, 6in, 1/2" Dia	2001705	EACH
30	16	Guardrail Bolt, 5/8" Dia, 1.14	4001145	EACH
31	16	Guardrail Nut, Received, 5/8" Dia, 1.14	4001146	EACH
32	16	C-Scr Nut, 1/2" Dia, 1.62" L, 6in, 1/2" Dia	3000131	EACH
33	16	C-Scr Nut, 1/2" Dia, 1.62" L, 6in, 1/2" Dia	3000132	EACH
34	10	Weldment, 1/2" Dia, 1.50" Dia, 0.63	2000036	EACH
35	15	Weldment, 1/2" Dia, 1.50" Dia, 0.63	2001409	EACH
36	15	Nut, 1/2" Dia, 1.62" L, 6in, 1/2" Dia	2000405	EACH
37	16	C-Scr Nut, 1/2" Dia, 1.62" L, 6in, 1/2" Dia	2000408	EACH
38	16	Weldment, 1/2" Dia, 1.50" Dia, 0.63	2000408	EACH
39	16	Weldment, 1/2" Dia, 1.50" Dia, 0.63	2000280	EACH
40	1	Nut, 1/2" Dia, 1.62" L, 6in, 1/2" Dia	2000345	EACH
41	1	Nut, 1/2" Dia, 1.62" L, 6in, 1/2" Dia	2000345	EACH
42	1	CHM Assembly, X-Tenuator, 1/2" Dia	2000123	EACH
43	2	CHM Assembly, X-Tenuator, 1/2" Dia	4002138	EACH

SCALE: 1:30

DATE: 02/09/10

DRAWN BY: JAF

APPROVED BY: JAF

TITLE: X-TENUATOR 100kph, NARROW

Standard Tolerance: 1/16" (0.0625")

Final: ± 0.10"

Dec: XX" ± 0.10"

Doc: XX" ± 0.030"

REV. 0 DATE 02/09/10 BY JAF

CHANGES: SEE ER # 815

REV. 1 DATE 02/09/10 BY JAF

CHANGES: SEE ER # 815

REV. 2 DATE 02/09/10 BY JAF

CHANGES: SEE ER # 815

REV. 3 DATE 02/09/10 BY JAF

CHANGES: SEE ER # 815

REV. 4 DATE 02/09/10 BY JAF

CHANGES: SEE ER # 815

REV. 5 DATE 02/09/10 BY JAF

CHANGES: SEE ER # 815

REV. 6 DATE 02/09/10 BY JAF

CHANGES: SEE ER # 815

REV. 7 DATE 02/09/10 BY JAF

CHANGES: SEE ER # 815

REV. 8 DATE 02/09/10 BY JAF

CHANGES: SEE ER # 815

REV. 9 DATE 02/09/10 BY JAF

CHANGES: SEE ER # 815

REV. 10 DATE 02/09/10 BY JAF

CHANGES: SEE ER # 815

REV. 11 DATE 02/09/10 BY JAF

CHANGES: SEE ER # 815

REV. 12 DATE 02/09/10 BY JAF

CHANGES: SEE ER # 815

REV. 13 DATE 02/09/10 BY JAF

CHANGES: SEE ER # 815

REV. 14 DATE 02/09/10 BY JAF

CHANGES: SEE ER # 815

REV. 15 DATE 02/09/10 BY JAF

CHANGES: SEE ER # 815

REV. 16 DATE 02/09/10 BY JAF

CHANGES: SEE ER # 815

REV. 17 DATE 02/09/10 BY JAF

CHANGES: SEE ER # 815

REV. 18 DATE 02/09/10 BY JAF

CHANGES: SEE ER # 815

REV. 19 DATE 02/09/10 BY JAF

CHANGES: SEE ER # 815

REV. 20 DATE 02/09/10 BY JAF

CHANGES: SEE ER # 815

REV. 21 DATE 02/09/10 BY JAF

CHANGES: SEE ER # 815

REV. 22 DATE 02/09/10 BY JAF

CHANGES: SEE ER # 815

REV. 23 DATE 02/09/10 BY JAF

CHANGES: SEE ER # 815

REV. 24 DATE 02/09/10 BY JAF

CHANGES: SEE ER # 815

REV. 25 DATE 02/09/10 BY JAF

CHANGES: SEE ER # 815

REV. 26 DATE 02/09/10 BY JAF

CHANGES: SEE ER # 815

REV. 27 DATE 02/09/10 BY JAF

CHANGES: SEE ER # 815

REV. 28 DATE 02/09/10 BY JAF

CHANGES: SEE ER # 815

REV. 29 DATE 02/09/10 BY JAF

CHANGES: SEE ER # 815

REV. 30 DATE 02/09/10 BY JAF

CHANGES: SEE ER # 815

REV. 31 DATE 02/09/10 BY JAF

CHANGES: SEE ER # 815

REV. 32 DATE 02/09/10 BY JAF

CHANGES: SEE ER # 815

REV. 33 DATE 02/09/10 BY JAF

CHANGES: SEE ER # 815

REV. 34 DATE 02/09/10 BY JAF

CHANGES: SEE ER # 815

REV. 35 DATE 02/09/10 BY JAF

CHANGES: SEE ER # 815

REV. 36 DATE 02/09/10 BY JAF

CHANGES: SEE ER # 815

REV. 37 DATE 02/09/10 BY JAF

CHANGES: SEE ER # 815

REV. 38 DATE 02/09/10 BY JAF

CHANGES: SEE ER # 815

REV. 39 DATE 02/09/10 BY JAF

CHANGES: SEE ER # 815

REV. 40 DATE 02/09/10 BY JAF

CHANGES: SEE ER # 815

REV. 41 DATE 02/09/10 BY JAF

CHANGES: SEE ER # 815

REV. 42 DATE 02/09/10 BY JAF

CHANGES: SEE ER # 815

REV. 43 DATE 02/09/10 BY JAF

CHANGES: SEE ER # 815

REV. 44 DATE 02/09/10 BY JAF

CHANGES: SEE ER # 815

REV. 45 DATE 02/09/10 BY JAF

CHANGES: SEE ER # 815

REV. 46 DATE 02/09/10 BY JAF

CHANGES: SEE ER # 815

REV. 47 DATE 02/09/10 BY JAF

CHANGES: SEE ER # 815

REV. 48 DATE 02/09/10 BY JAF

CHANGES: SEE ER # 815

REV. 49 DATE 02/09/10 BY JAF

CHANGES: SEE ER # 815

REV. 50 DATE 02/09/10 BY JAF

CHANGES: SEE ER # 815

REV. 51 DATE 02/09/10 BY JAF

CHANGES: SEE ER # 815

REV. 52 DATE 02/09/10 BY JAF

CHANGES: SEE ER # 815

REV. 53 DATE 02/09/10 BY JAF

CHANGES: SEE ER # 815

REV. 54 DATE 02/09/10 BY JAF

CHANGES: SEE ER # 815

REV. 55 DATE 02/09/10 BY JAF

CHANGES: SEE ER # 815

REV. 56 DATE 02/09/10 BY JAF

CHANGES: SEE ER # 815

REV. 57 DATE 02/09/10 BY JAF

CHANGES: SEE ER # 815

REV. 58 DATE 02/09/10 BY JAF

CHANGES: SEE ER # 815

REV. 59 DATE 02/09/10 BY JAF

CHANGES: SEE ER # 815

REV. 60 DATE 02/09/10 BY JAF

CHANGES: SEE ER # 815

REV. 61 DATE 02/09/10 BY JAF

CHANGES: SEE ER # 815

REV. 62 DATE 02/09/10 BY JAF

CHANGES: SEE ER # 815

REV. 63 DATE 02/09/10 BY JAF

CHANGES: SEE ER # 815

REV. 64 DATE 02/09/10 BY JAF

CHANGES: SEE ER # 815

REV. 65 DATE 02/09/10 BY JAF

CHANGES: SEE ER # 815

REV. 66 DATE 02/09/10 BY JAF

CHANGES: SEE ER # 815

REV. 67 DATE 02/09/10 BY JAF

CHANGES: SEE ER # 815

REV. 68 DATE 02/09/10 BY JAF

CHANGES: SEE ER # 815

REV. 69 DATE 02/09/10 BY JAF

CHANGES: SEE ER # 815

REV. 70 DATE 02/09/10 BY JAF

CHANGES: SEE ER # 815

REV. 71 DATE 02/09/10 BY JAF

CHANGES: SEE ER # 815

REV. 72 DATE 02/09/10 BY JAF

CHANGES: SEE ER # 815

REV. 73 DATE 02/09/10 BY JAF

CHANGES: SEE ER # 815

REV. 74 DATE 02/09/10 BY JAF

CHANGES: SEE ER # 815

REV. 75 DATE 02/09/10 BY JAF

CHANGES: SEE ER # 815

REV. 76 DATE 02/09/10 BY JAF

CHANGES: SEE ER # 815

REV. 77 DATE 02/09/10 BY JAF

CHANGES: SEE ER # 815

REV. 78 DATE 02/09/10 BY JAF

CHANGES: SEE ER # 815

REV. 79 DATE 02/09/10 BY JAF

CHANGES: SEE ER # 815

REV. 80 DATE 02/09/10 BY JAF

CHANGES: SEE ER # 815

REV. 81 DATE 02/09/10 BY JAF

CHANGES: SEE ER # 815

REV. 82 DATE 02/09/10 BY JAF

CHANGES: SEE ER # 815

REV. 83 DATE 02/09/10 BY JAF

CHANGES: SEE ER # 815

REV. 84 DATE 02/09/10 BY JAF

CHANGES: SEE ER # 815

REV. 85 DATE 02/09/10 BY JAF

CHANGES: SEE ER # 815

REV. 86 DATE 02/09/10 BY JAF

CHANGES: SEE ER # 815

REV. 87 DATE 02/09/10 BY JAF

CHANGES: SEE ER # 815

REV. 88 DATE 02/09/10 BY JAF

CHANGES: SEE ER # 815

REV. 89 DATE 02/09/10 BY JAF

CHANGES: SEE ER # 815

REV. 90 DATE 02/09/10 BY JAF

CHANGES: SEE ER # 815

REV. 91 DATE 02/09/10 BY JAF

CHANGES: SEE ER # 815

REV. 92 DATE 02/09/10 BY JAF

CHANGES: SEE ER # 815

REV. 93 DATE 02/09/10 BY JAF

CHANGES: SEE ER # 815

REV. 94 DATE 02/09/10 BY JAF

CHANGES: SEE ER # 815

REV. 95 DATE 02/09/10 BY JAF

CHANGES: SEE ER # 815

REV. 96 DATE 02/09/10 BY JAF

CHANGES: SEE ER # 815

REV. 97 DATE 02/09/10 BY JAF

CHANGES: SEE ER # 815

REV. 98 DATE 02/09/10 BY JAF

CHANGES: SEE ER # 815

REV. 99 DATE 02/09/10 BY JAF

CHANGES: SEE ER # 815

REV. 100 DATE 02/09/10 BY JAF

CHANGES: SEE ER # 815

Appendix A - System Configuration

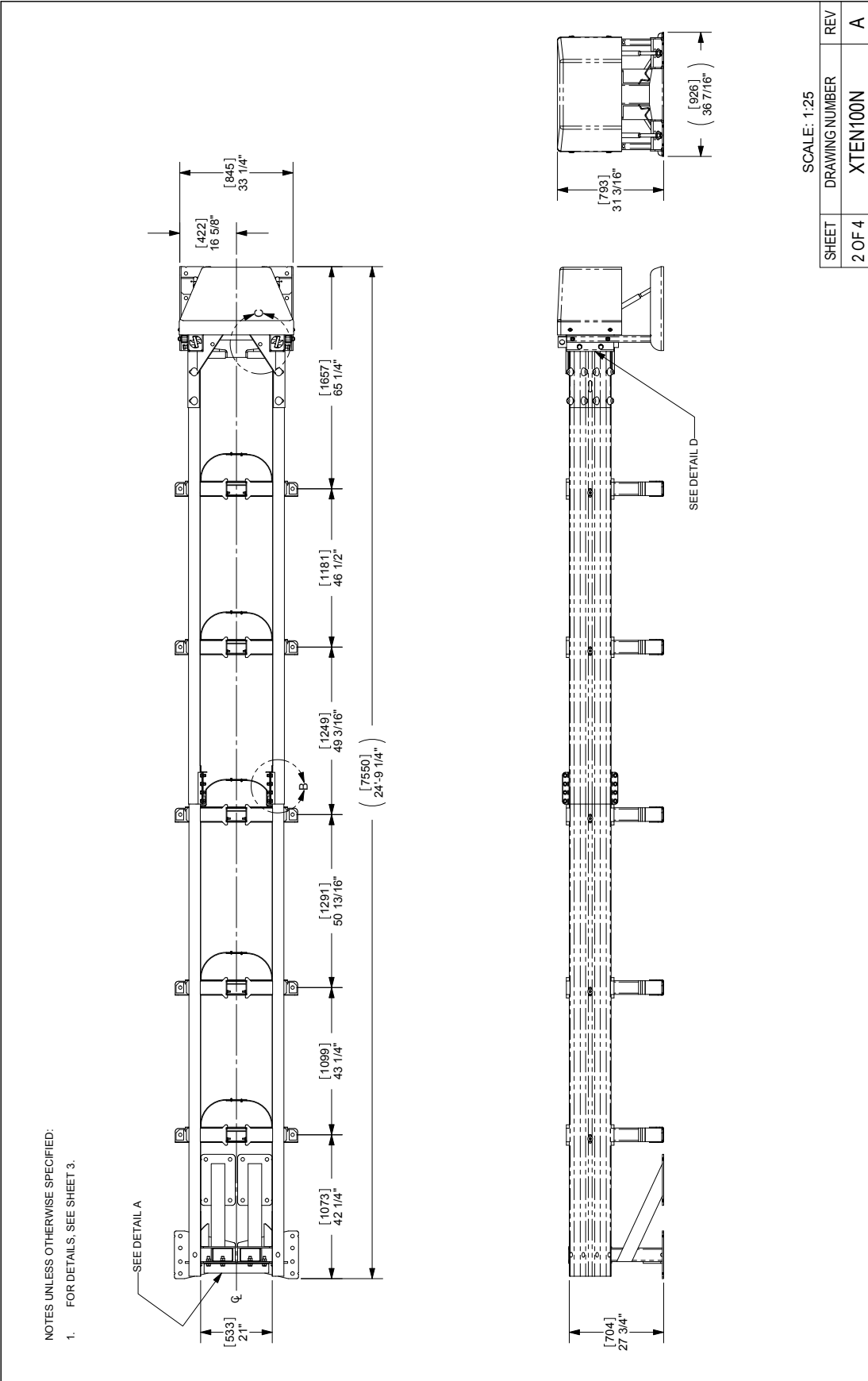

SCALE: 1:25

SHEET	DRAWING NUMBER	REV
2 OF 4	XTEN100N	A

Appendix A - System Configuration

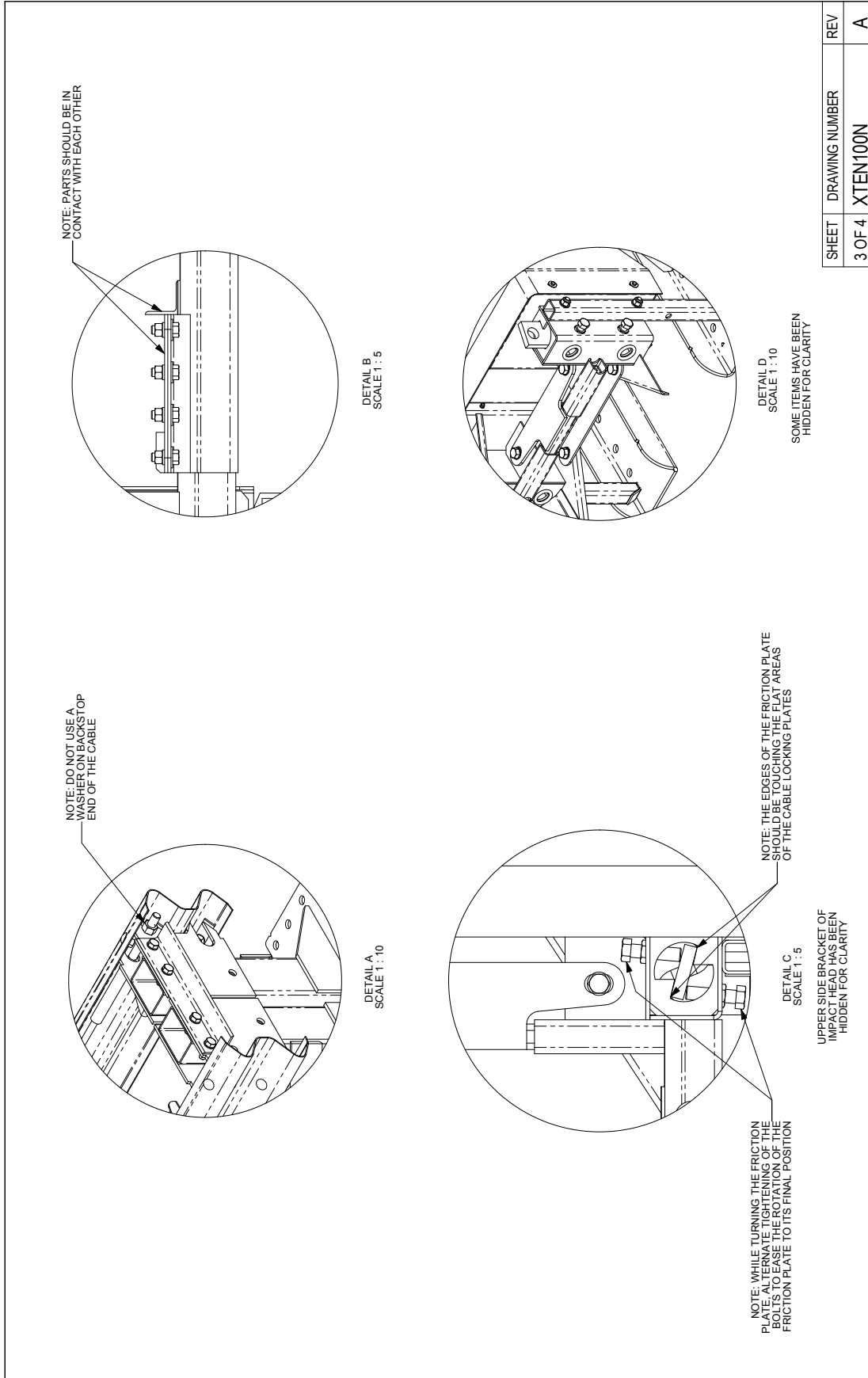

Appendix A - System Configuration

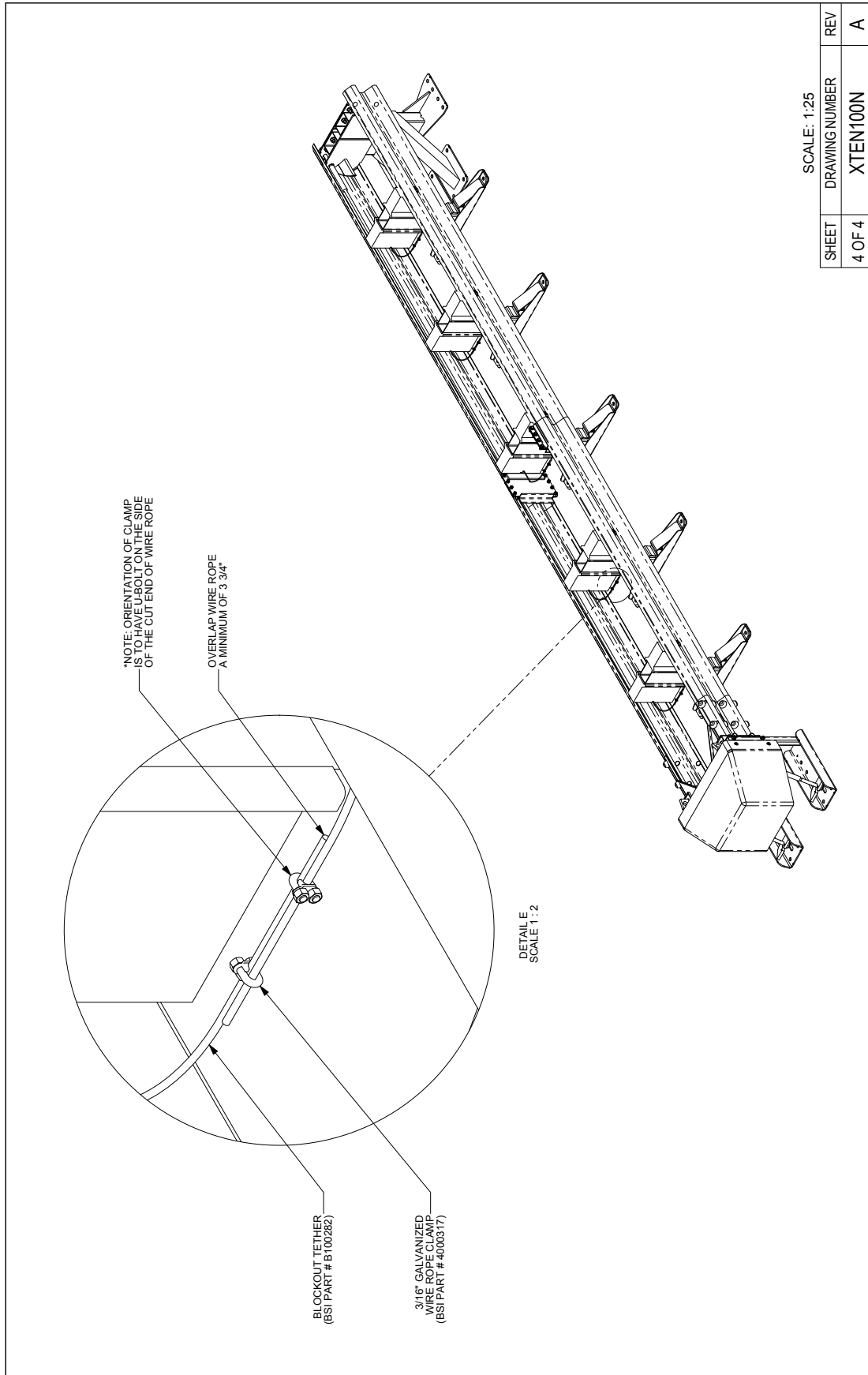

Appendix A - System Configuration

Bill of Materials			
Item	Part No.	Description	Quantity
1	B100238	Nose Cover, X-TENUator	1
2	B100239	EA Nose Cartridge, X-TENUator	1
3	B100244	Cable Anchor Weldment,	2
4	B061072	Head Unit Weldment, X350	2
5	B100348	Cable Friction Plate,	2
6	B100247	Upper Head Support Weldment,	1
7	B100250	Lower Head Support Plate,	1
8	B100251	Head Support Leg Weldment,	2
9	B100254	Leaning Post Weldment,	5
10	B090534	W-Beam Composite Blockout 8in,	10
11	B100259	Front Panel Weldment,	2
12	B100346	Slider Brace Weldment, Front	2
13	B100263	Back Panel Weldment,	2
14	B100266	Backstop Weldment, Right	1
15	B100267	Backstop Weldment, Left	1
16	B100280	Brace, Backstop, X-TENUator	1
17	B100281	Cable Assembly, X-TENUator	2
18	2001615	C-Scr HH M20-2.5x75mm Gr 5.8	8
19	2000298	C-Scr HH 1/4-20x1 Gr2 MGal	10
20	2000263	Wshr Fender 1/4x1.0 ODx.063	6
21	2001446	Wshr 1/4 Flat Rd Galv	14
22	2000274	Nut HN 1/4-20 MGal	10
23	2000250	C-Scr HH 5/8-11x3 1/4 Gr2 MGal	4
24	2000118	Wshr 5/8 F436 Struct Galv	8
25	2000134	Nut HN 5/8-11 A563 Gr2 Gal	4
26	2001633	C-Scr HH 3/4-10x2 1/2 Gr5 MGal	2
27	2000398	C-Scr HH 3/4-10x2 1/4 Gr5 MGal	6
28	2001634	Wshr 3/4 F436 Flat Rd Struct,	16
29	2001705	Nut HN 3/4-10 MGal	8
30	4001115	Guardrail Bolt 5/8-11x 1 1/4	16
31	4001116	Guardrail Nut Recessed 5/8-11	16
32	B080755	PLASTIC NUT PROTECTOR	16
33	2000121	C-Scr HH 3/8-16x9 Gr5 MGal	10
34	2000096	Wshr Fender 3/8 x 1.5OD x .063	10
35	2001409	Wshr 3/8 Flat Rd SAE Galv	15
36	2000405	Nut HN 3/8-16 Gr5 Gal	15
37	2000279	C-Scr HH 1/2-13x1 1/4 Gr5 MGal	16
38	2001408	Wshr 1/2 Flat Rd SAE Galv	16
39	2000280	Wshr SL 1/2 MGal	16
40	2000305	Nut HN 1/2-13 Gr5 MGal	16
41	K080123	Kit, X-Tension Shear Bolt,	1
42	K100201	Tether Kit, X-TENUator	1
43	4002138	Cable Tie 15x1/4 dia UV Blk	2
44	MANXTEN1	X-TENUATOR Installation Manual	0

Appendix A - System Configuration

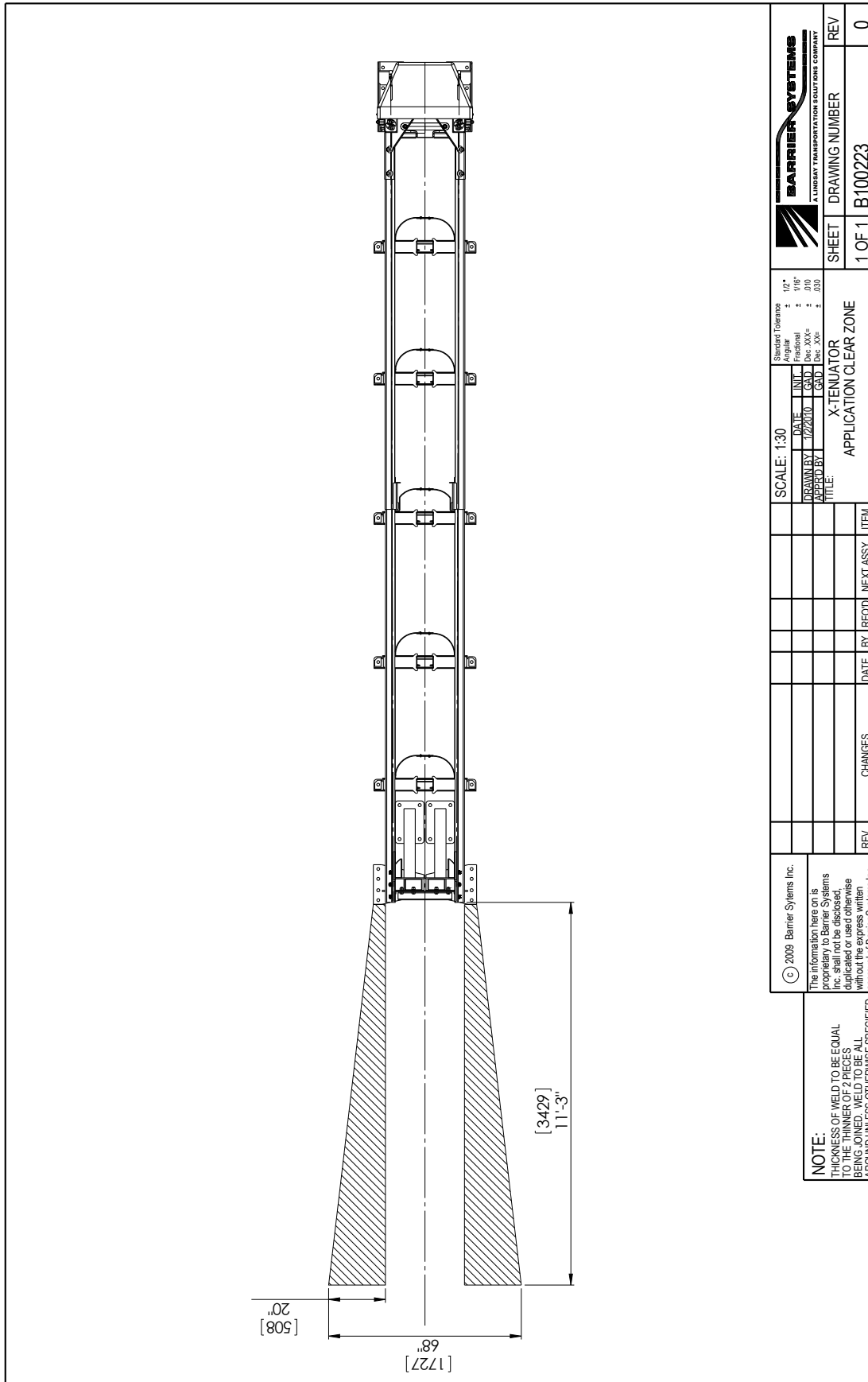

Appendix B - Anchoring Foundation Options

There are two approved X-TENUator System anchoring foundation configurations for the X-TENUator System. The first method utilizes a solid reinforced concrete pad over the length of the system. The second is on Asphaltic Concrete foundation.

(Variations of these foundations may be reviewed and determinations made as to equivalence by the Project Engineer.)

Foundation options and system layouts are shown in the following drawings.

DRAWINGS

Foundation Pad PCC Concrete DWG# B100303	40
Foundation Pad Asphaltic Concrete (AC) DWG# B100304	41

Appendix B - Anchoring Foundation Options

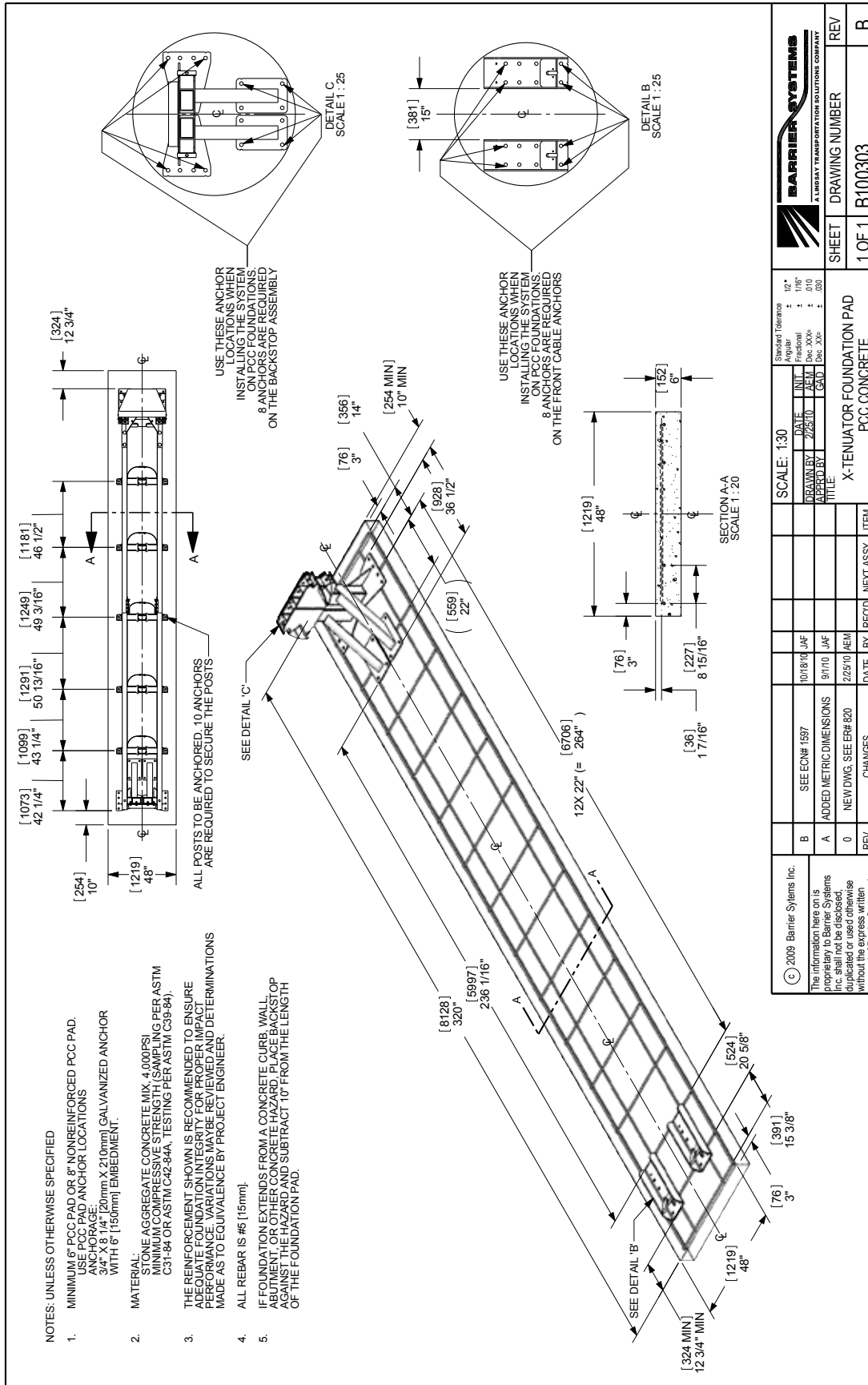

Barrier Systems <small>A LINDSAY TRANSPORTATION SOLUTIONS COMPANY</small>		Standard Tolerance Angular: ± 1/2° Fractional: ± 1/16" Dec. XX": ± 0/10" Dec. XX": ± 0.00" Dec. XX": ± 0.00" Dec. XX": ± 0.00"	SHEET: 1 OF 1 DRAWING NUMBER: B100303 REV: B
SCALE: 1:30 DATE: 2/25/10 DRAWN BY: JAF CHECKED BY: JAF TITLE: X-TENUATOR FOUNDATION PAD PCC CONCRETE	SEE ECR# 1597 10/18/10 JAF 9/1/10 JAF 2/25/10 JAF	REV. 0 CHANGES: NEW DWG. SEE ERF 620	REV. 0 DATE: 2/25/10 BY: JAF RECD: JAF NEXT ASSY. ITEM:

Appendix B - Anchoring Foundation Options

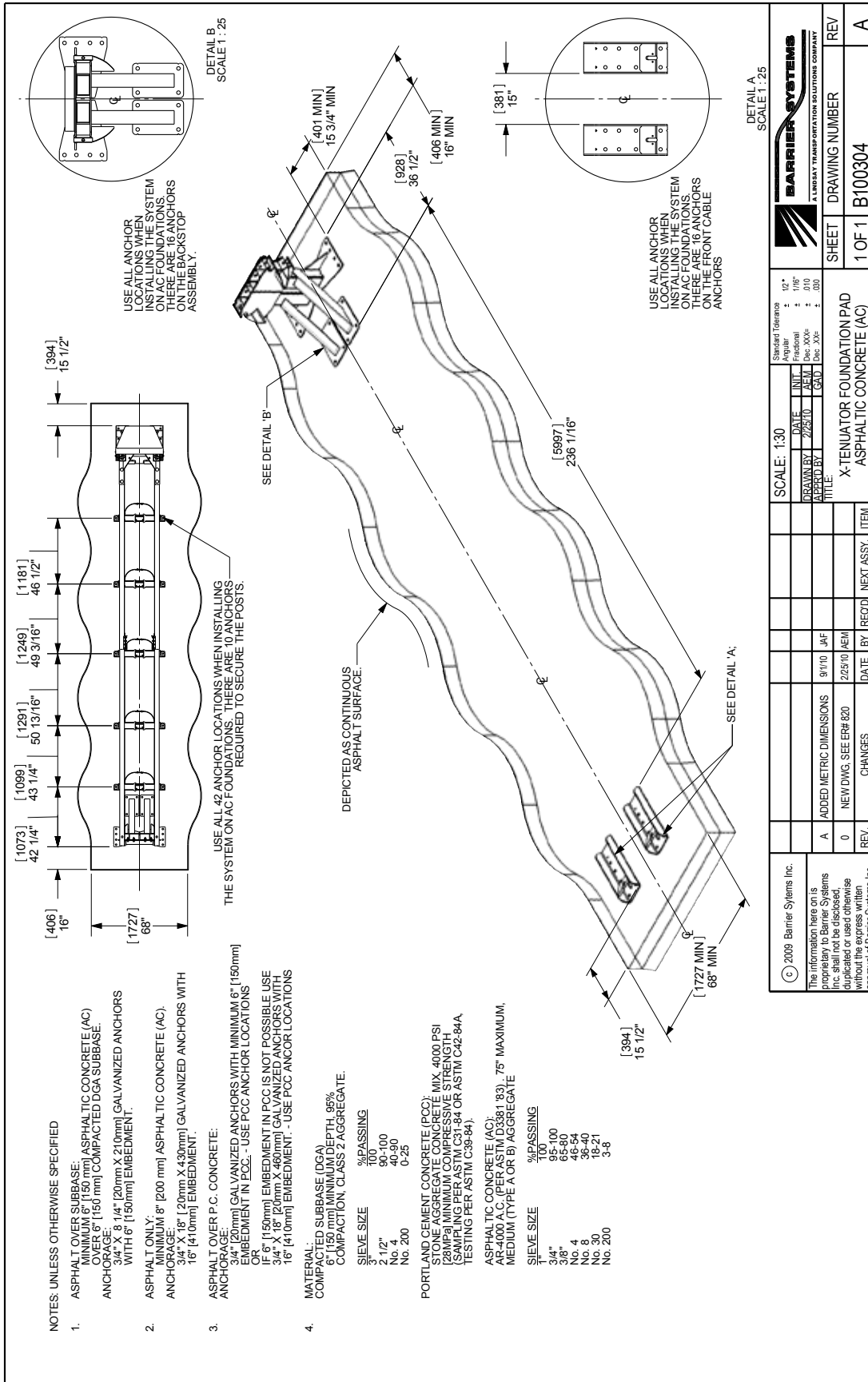

Appendix C - Transitions

There are a variety of transition options available for the X-TENUator System. The system was designed to be compatible with a variety of generic transitions already available to the industry.

Placement and installation of the X-TENUator System and transitions must be accomplished in accordance with the guidelines and recommendations set forth in the “AASHTO Roadside Design Guide,” FHWA memoranda and other state and local standards.

A special transition adapter bracket is required whenever using a transition. Refer to section “Install Transition Bracket,” Page 30.

Transition options are shown in the following drawings.

DRAWINGS

Transition Adapter Bracket DWG# BSI-1007020-KT	43
Transition to PCB, Unidirectional DWG# B091110	44
Transition to PCB, Bidirectional, Centered DWG# B091111	45
Transition to PCB, Bidirectional, Offset DWG# B091112	46
Transition to W-Beam, Roadside Approach DWG# B091113	47
Transition to W-Beam, Roadside Departure DWG# B091114	48
Transition to W-Beam, Median DWG# B091115	49
Transition to Thrie-Beam, Roadside Approach DWG# B091116	50
Transition to Thrie-Beam, Roadside Departure DWG# B091117	51
Transition to Thrie-Beam, Median DWG# B091118	52

Appendix C Transitions

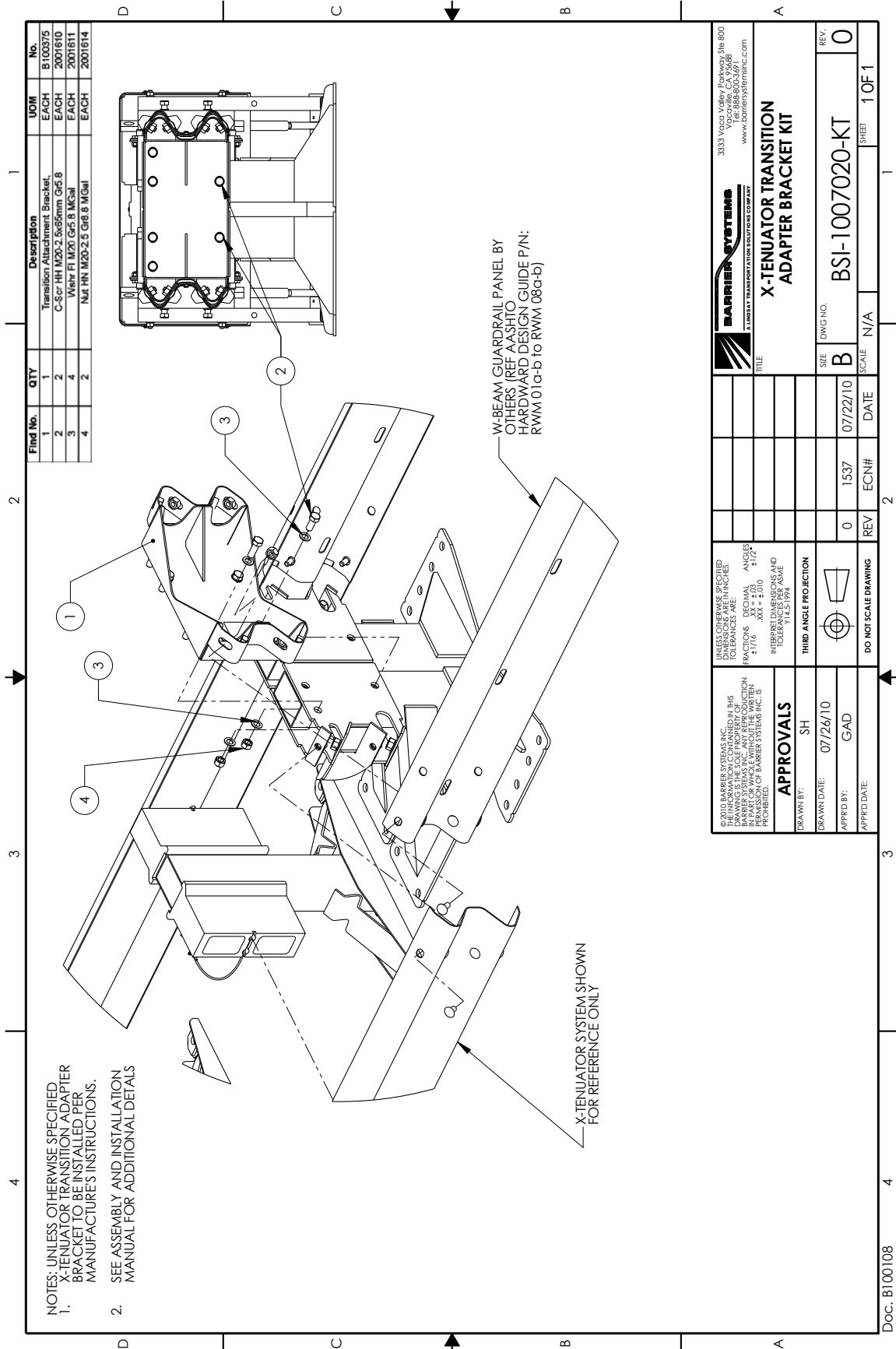

NOTES: UNLESS OTHERWISE SPECIFIED,
 X-TENUATOR TRANSITION ADAPTER
 BRACKET TO BE INSTALLED PER
 MANUFACTURE'S INSTRUCTIONS.
 2. SEE ASSEMBLY AND INSTALLATION
 MANUAL FOR ADDITIONAL DETAILS

X-TENUATOR SYSTEM SHOWN
 FOR REFERENCE ONLY

W-BEAM GUARDRAIL PANEL BY
 OTHERS (REF AASHIO
 HARDWARD DESIGN GUIDE P/N:
 RWM01a-b to RWM 08a-b)

BARRIER SYSTEMS A LINDSAY TRANSPORTATION SOLUTIONS COMPANY 3333 VOUGLIS WAY, FISHKILL, NY 12524 TEL: 888-800-3691 WWW.BARRIERSYSTEMS.COM	
TITLE: X-TENUATOR TRANSITION ADAPTER BRACKET KIT	
UNLESS OTHERWISE SPECIFIED, DIMENSIONS ARE IN INCHES. TOLERANCES ARE: XX = ±.03 XXX = ±.010 FINISH: XX = 1/2 XXX = 1/2	
INTERPRET DIMENSIONS AND TOLERANCES TO THE 2011 ASME Y14.5, 2011 Y14.5, 1994	THIRD ANGLE PROJECTION
APPROVALS	DO NOT SCALE DRAWING
DRAWN BY: SH	REV: 0
DRAWN DATE: 07/26/10	ECN#: 1537
APPRD BY: G-AD	DATE: 07/22/10
APPRD DATE:	SCALE: N/A
	SHEET: 1 OF 1

Doc. B100108

Appendix C Transitions

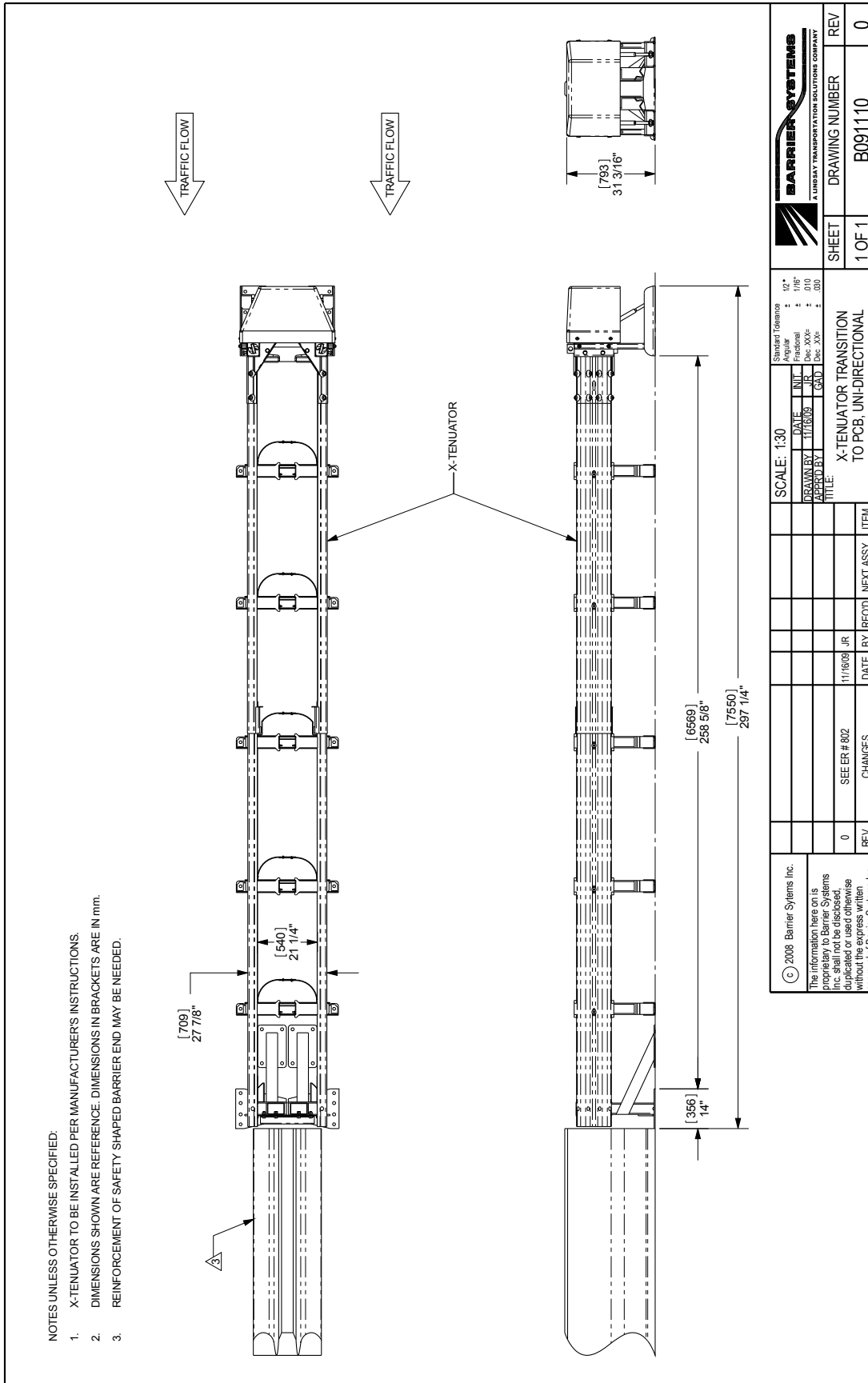

		Standard Tolerance Angular: ± 1/2° Fractional: ± 1/16" Dec. XX": ± 0.10 Dec. XX": ± 0.02	SHEET 1 OF 1	DRAWING NUMBER B091110	REV 0
SCALE: 1:30 DATE: 11/16/09 DRAWN BY: JT/BJR CHECKED BY: GAD, JAC, JSD	TITLE: X-TENUATOR TRANSITION TO PCB, UNI-DIRECTIONAL				
0 SEE ER # 802 CHANGES	11/16/09 JR	DATE BY	RECD NEXT ASSY. ITEM	REV.	
© 2008 Barrier Systems Inc. The information here on is proprietary to Barrier Systems Inc. shall not be disclosed, duplicated or used otherwise without the express written approval of Barrier Systems Inc.					

Appendix C Transitions

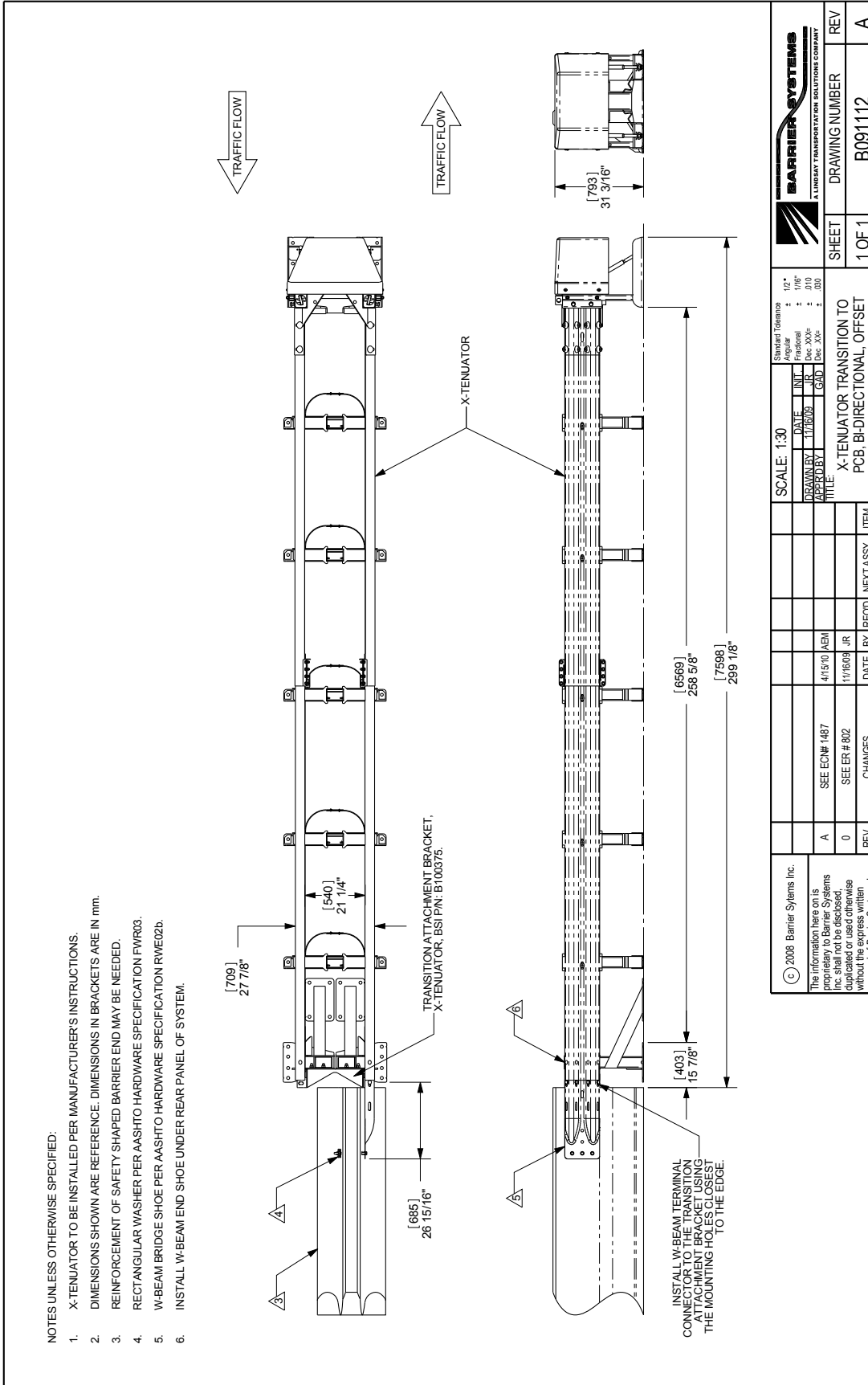

NOTES UNLESS OTHERWISE SPECIFIED:

1. X-TENUATOR TO BE INSTALLED PER MANUFACTURER'S INSTRUCTIONS.
2. DIMENSIONS SHOWN ARE REFERENCE. DIMENSIONS IN BRACKETS ARE IN mm.
3. REINFORCEMENT OF SAFETY SHAPED BARRIER END MAY BE NEEDED.
4. RECTANGULAR WASHER PER AASHTO HARDWARE SPECIFICATION FWR03.
5. W-BEAM BRIDGE SHOE PER AASHTO HARDWARE SPECIFICATION RW02b.
6. INSTALL W-BEAM END SHOE UNDER REAR PANEL OF SYSTEM.

		Standard Tolerances Angular ± 1/2° Fractional ± 1/16" Dec. XX ± .005 Dec. XX ± .009	SCALE: 1:30	DATE: 11/17/09 DRAWN BY: JLR CHECKED BY: GAD	SHEET: 1 OF 1	DRAWING NUMBER: B091112	REV: A
© 2008 Barrier Systems Inc. The information here on is proprietary to Barrier Systems Inc. shall not be disclosed, duplicated or used otherwise without the express written approval of Barrier Systems Inc.		TITLE: X-TENUATOR TRANSITION TO PCB, BI-DIRECTIONAL, OFFSET	SEE ECR# 1487 SEE ECR # 802	DATE: 4/15/10 AEM DATE: 11/16/09 JLR	REV: 0 CHANGES	BY: JLR RECD:	ITEM:

Appendix C Transitions

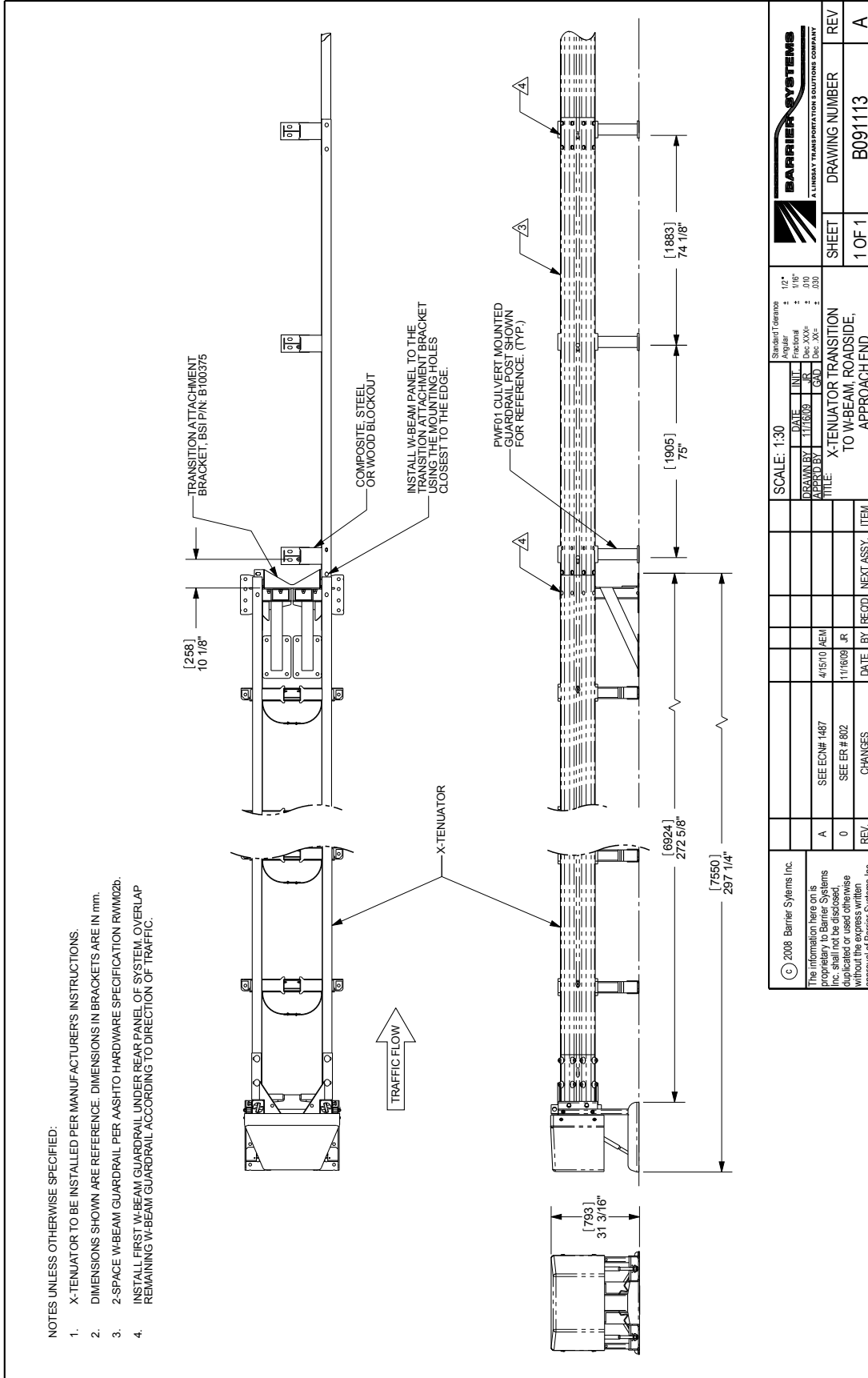

NOTES UNLESS OTHERWISE SPECIFIED:

1. X-TENUATOR TO BE INSTALLED PER MANUFACTURER'S INSTRUCTIONS.
2. DIMENSIONS SHOWN ARE REFERENCE. DIMENSIONS IN BRACKETS ARE IN MM.
3. 2-SPACE W-BEAM GUARDRAIL PER AASHTO HARDWARE SPECIFICATION RWM02b.
4. INSTALL FIRST W-BEAM GUARDRAIL UNDER REAR PANEL OF SYSTEM. OVERLAP REMAINING W-BEAM GUARDRAIL ACCORDING TO DIRECTION OF TRAFFIC.

		Standard Tolerances Angular: ± 1/2° Fractional: ± 1/16" Dec. XXX: ± .010 Dec. XXXX: ± .005	
SCALE: 1:30	DATE: 1/16/09	DESIGNED BY: JLR	DRAWN BY: JLR
SEE ECNR # 1487	4/15/10 AEM	RECD: JLR	BY: JLR
SEE ER # 802	1/16/09 JR	CHANGES	DATE
REV. 0	REV. 1	REV. 2	REV. 3
SEE ER # 802	1/16/09 JR	CHANGES	DATE
SEE ECNR # 1487	4/15/10 AEM	RECD: JLR	BY: JLR
DATE: 1/16/09	DESIGNED BY: JLR	DRAWN BY: JLR	SCALE: 1:30
TITLE: X-TENUATOR TRANSITION TO W-BEAM, ROADSIDE, APPROACH END			
SHEET 1 OF 1	DRAWING NUMBER B091113	REV A	REV A

Appendix C Transitions

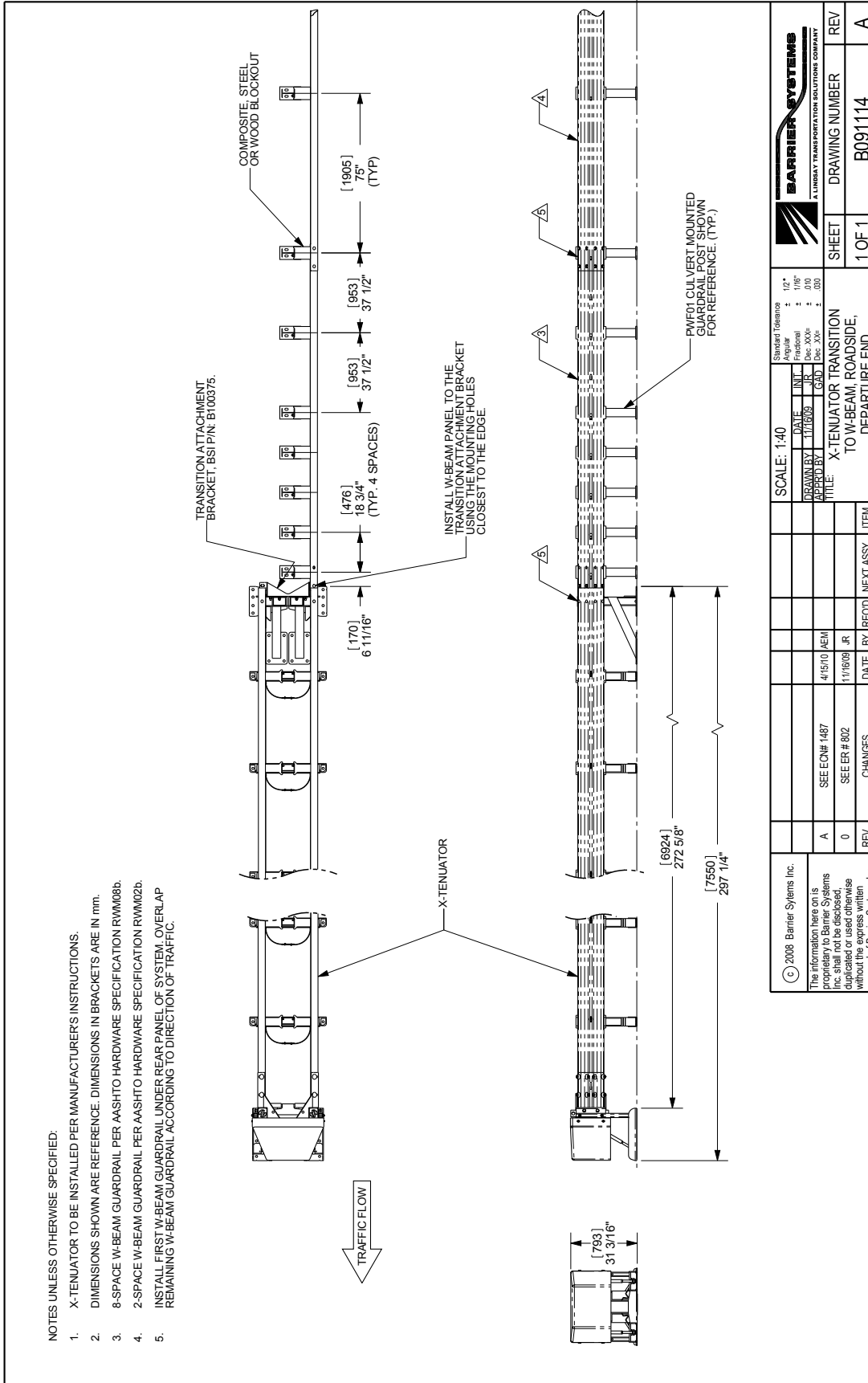

NOTES UNLESS OTHERWISE SPECIFIED:

1. X-TENUATOR TO BE INSTALLED PER MANUFACTURERS INSTRUCTIONS.
2. DIMENSIONS SHOWN ARE REFERENCE. DIMENSIONS IN BRACKETS ARE IN mm.
3. 8-SPACE W-BEAM GUARDRAIL PER AASHTO HARDWARE SPECIFICATION RWM08b.
4. 2-SPACE W-BEAM GUARDRAIL PER AASHTO HARDWARE SPECIFICATION RWM02b.
5. INSTALL FIRST W-BEAM GUARDRAIL UNDER REAR PANEL OF SYSTEM. OVERLAP REMAINING W-BEAM GUARDRAIL ACCORDING TO DIRECTION OF TRAFFIC.

		Standard Tolerances Angular: ± 1/2° Fractional: ± 1/16" Decimals: ± .010 Hole: +.003 Shaft: -.003	
SCALE: 1:40	DATE: 1/16/09	DESIGNED BY: J. CARL	DRAWN BY: J. CARL
SEE ECNF 1487	4/15/10 AEM	SEE ER # 802	1/16/09 JR
0	CHANGES	REV.	DATE BY RECD
© 2008 Barrier Systems Inc. The information here on is proprietary to Barrier Systems Inc. shall not be disclosed, duplicated or used otherwise without the express written approval of Barrier Systems Inc.		TITLE: X-TENUATOR TRANSITION TO W-BEAM ROADSIDE, DEPARTURE END	
REV. A	SEE ECNF 1487	SEE ER # 802	1/16/09 JR
0	CHANGES	REV.	DATE BY RECD
1 OF 1	DRAWING NUMBER	B091114	REV. A

Appendix C Transitions

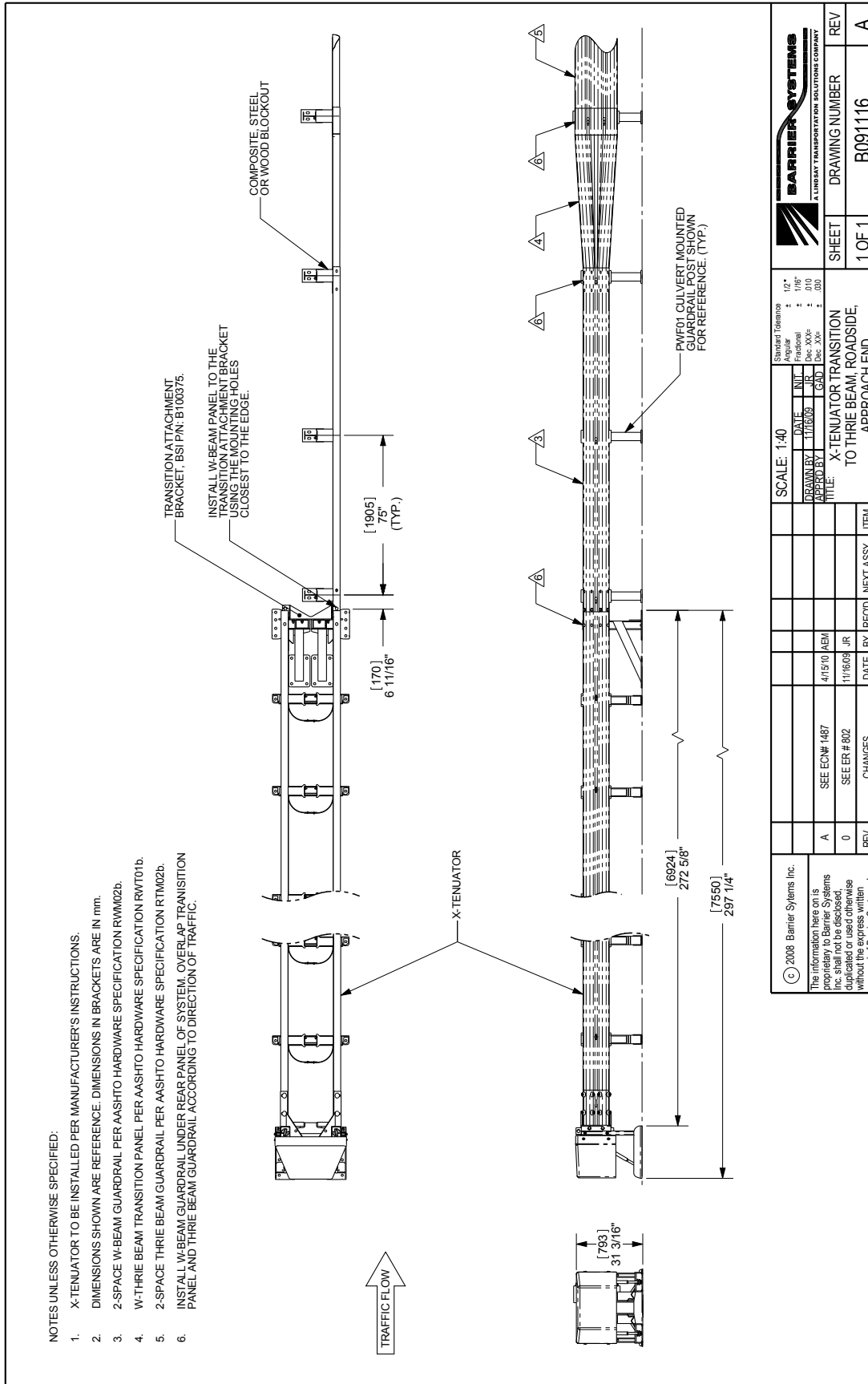

Appendix C Transitions

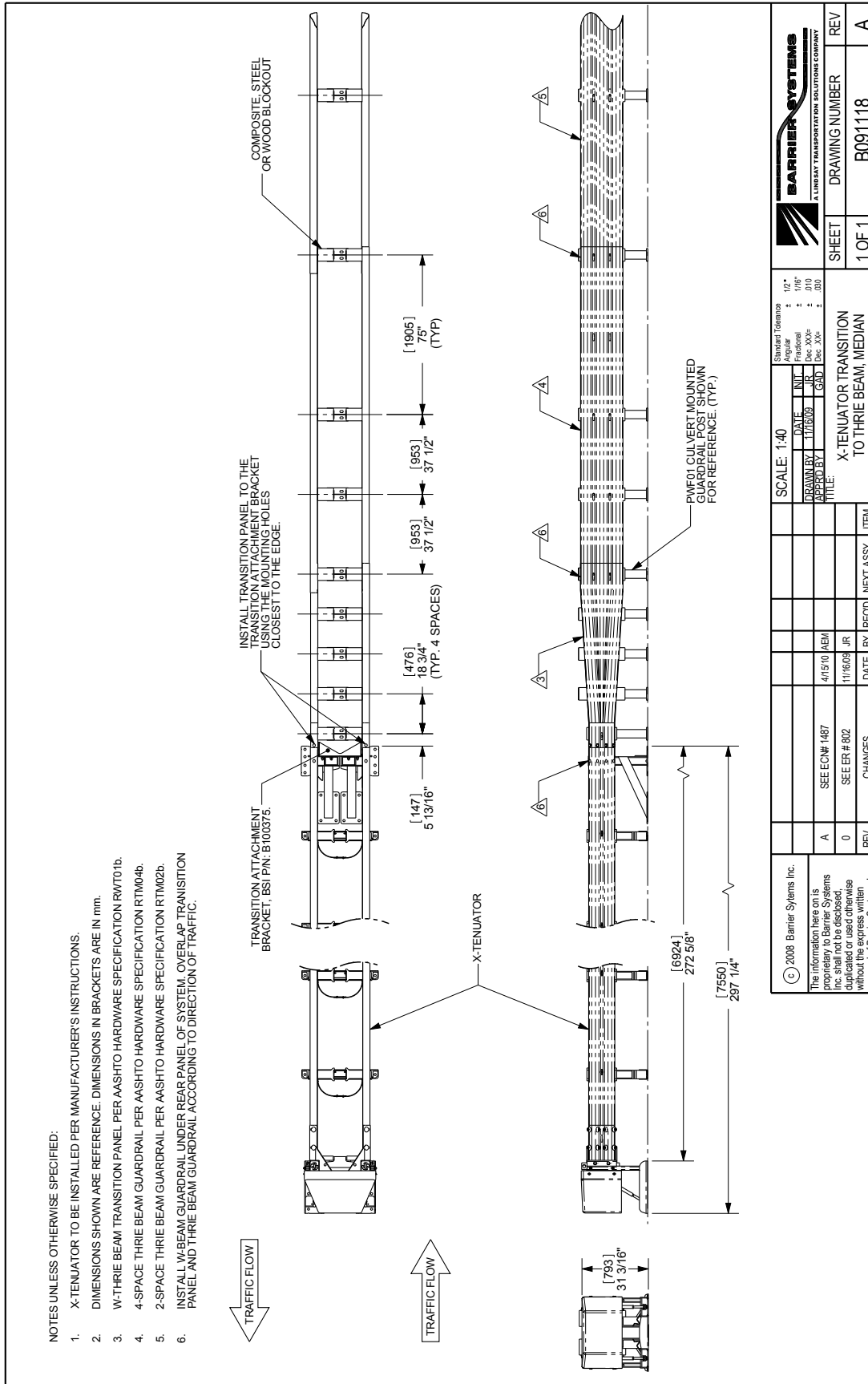

		Standard Tolerances Angular ± 1/2° Fractional ± 1/16" Dec: XX± ± .005 Dec: .XX± ± .003
SCALE: 1:40	DATE: 11/16/09	DRAWN BY: JR
CHECKED BY: JR	DATE: 4/15/10	AEM
TITLE: X-TENUATOR TRANSITION TO THREE BEAM, MEDIAN	DATE: 11/16/09	JR
REV. 0	CHANGES	REV.
SEE ECN# 1487	SEE ER # 802	REV.
© 2008 Barrier Systems Inc.	The information here on is proprietary to Barrier Systems Inc. shall not be disclosed, duplicated or used otherwise without the express written approval of Barrier Systems Inc.	REV.
SHEET 1 OF 1	DRAWING NUMBER B091118	REV A

Page Left Intentionally Blank

Page Left Intentionally Blank

Page Left Intentionally Blank



Lindsay Transportation Solutions Sales and Services, Inc

180 River Road • Rio Vista, CA 94571 • +1 707.374.6800 U.S. Toll Free: 888.800.3691 • www.barrriersystemsinc.com

Installation manual details for the X-TENUATOR System are subject to change without notice to reflect improvements and upgrades.

Additional information is available from Lindsay Transportation Solutions Sales and Service © Lindsay Transportation Solutions

X-TENUATOR INSTALLATION 07022014 v4