

TFBB04 1:2

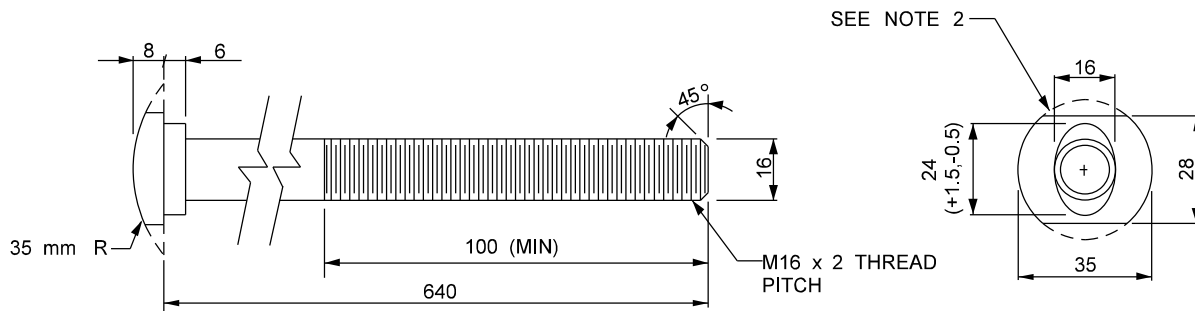

TFBB05 1:2

NOTES:

1. ALL FILLETS SHALL HAVE A MINIMUM RADIUS OF 2.
2. FULLY CIRCULAR "BUTTON HEAD" BOLT IS ACCEPTABLE.
3. SEE TFBB01 FOR ACCOMPANYING NUT.
4. ALL SCALES ARE APPROXIMATE.
5. ALL DIMENSIONS ARE IN MILLIMETERS.
6. THE ORIGINAL SEALED & SIGNED DRAWING IS IN TRAFFIC ENGINEERING.

REVISIONS		
DATE	DESCRIPTION	BY
10-2010	REVISIONS	DC
05-2013	LENGTH OF THREAD	DC

Manitoba 
Infrastructure and Transportation
 TRAFFIC ENGINEERING



GUARDRAIL BOLT
AND RECESSED NUT

SHEET NO:	1 OF 1
DATE:	2006 - 11
DRAWN:	A.G.

TFBB04-05